

Chapter 4 Trigonometry and the Unit Circle

Section 4.1 Angles and Angle Measure

Section 4.1 Page 175 Question 1

- a) -4π is a clockwise rotation
- b) 750° is a counterclockwise rotation
- c) -38.7° is a clockwise rotation
- d) 1 radian is a counterclockwise rotation

Section 4.1 Page 175 Question 2

a) $30^\circ = 30 \left(\frac{\pi}{180} \right)$
 $= \frac{\pi}{6}$

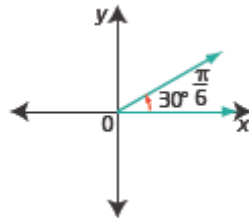

b) $45^\circ = 45 \left(\frac{\pi}{180} \right)$
 $= \frac{\pi}{4}$

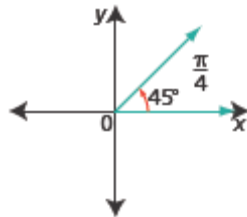

c) $-330^\circ = -330 \left(\frac{\pi}{180} \right)$
 $= -\frac{11\pi}{6}$

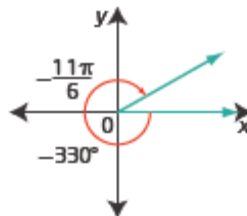

d) $520^\circ = 520 \left(\frac{\pi}{180} \right)$
 $= \frac{26\pi}{9}$

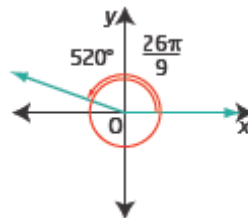

$$\begin{aligned} \text{e) } 90^\circ &= 90 \left(\frac{\pi}{180} \right) \\ &= \frac{\pi}{2} \end{aligned}$$

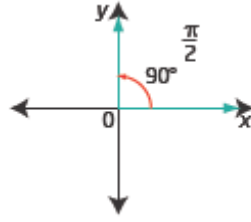

$$\begin{aligned} \text{f) } 21^\circ &= 21 \left(\frac{\pi}{180} \right) \\ &= \frac{7\pi}{60} \end{aligned}$$

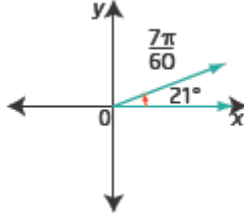

Section 4.1 Page 175

Question 3

$$\begin{aligned} \text{a) } 60^\circ &= 60 \left(\frac{\pi}{180} \right) \\ &= \frac{\pi}{3} \\ &\approx 1.05 \end{aligned}$$

$$\begin{aligned} \text{b) } 150^\circ &= 150 \left(\frac{\pi}{180} \right) \\ &= \frac{5\pi}{6} \\ &\approx 2.62 \end{aligned}$$

$$\begin{aligned} \text{c) } -270^\circ &= -270 \left(\frac{\pi}{180} \right) \\ &= -\frac{3\pi}{2} \\ &\approx -4.71 \end{aligned}$$

$$\begin{aligned} \text{d) } 72^\circ &= 72 \left(\frac{\pi}{180} \right) \\ &= \frac{2\pi}{5} \\ &\approx 1.26 \end{aligned}$$

$$\begin{aligned} \text{e) } -14.8^\circ &= -14.8 \left(\frac{\pi}{180} \right) \\ &= -\frac{148\pi}{1800} \\ &= -\frac{37\pi}{450} \\ &\approx -0.26 \end{aligned}$$

$$\begin{aligned} \text{f) } 540^\circ &= 540 \left(\frac{\pi}{180} \right) \\ &= 3\pi \\ &\approx 9.42 \end{aligned}$$

Section 4.1 Page 175

Question 4

$$\begin{aligned} \text{a) } \frac{\pi}{6} &= \frac{180^\circ}{6} \\ &= 30^\circ \end{aligned}$$

$$\begin{aligned} \text{b) } \frac{2\pi}{3} &= \frac{2(180^\circ)}{3} \\ &= 120^\circ \end{aligned}$$

$$\begin{aligned} \text{c) } -\frac{3\pi}{8} &= -\frac{3(180^\circ)}{8} \\ &= -67.5^\circ \end{aligned}$$

$$\begin{aligned} \text{d) } -\frac{5\pi}{2} &= -\frac{5(180^\circ)}{2} \\ &= -450^\circ \end{aligned}$$

$$\begin{aligned} \text{e) } 1 &= 1 \left(\frac{180^\circ}{\pi} \right) \\ &= \frac{180^\circ}{\pi} \\ &\approx 57.3^\circ \end{aligned}$$

$$\begin{aligned} \text{f) } 2.75 &= 2.75 \left(\frac{180^\circ}{\pi} \right) \\ &= \frac{495^\circ}{\pi} \\ &\approx 157.6^\circ \end{aligned}$$

Section 4.1 Page 175

Question 5

$$\begin{aligned} \text{a) } \frac{2\pi}{7} &= \frac{2(180^\circ)}{7} \\ &= \frac{360^\circ}{7} \\ &\approx 51.429^\circ \end{aligned}$$

$$\begin{aligned} \text{b) } \frac{7\pi}{13} &= \frac{7(180^\circ)}{13} \\ &= \frac{1260^\circ}{13} \\ &\approx 96.923^\circ \end{aligned}$$

$$\begin{aligned} \text{c) } \frac{2}{3} &= \frac{2}{3} \left(\frac{180^\circ}{\pi} \right) \\ &= \frac{120^\circ}{\pi} \\ &\approx 38.197^\circ \end{aligned}$$

$$\begin{aligned} \text{d) } 3.66 &= 3.66 \left(\frac{180^\circ}{\pi} \right) \\ &= \frac{658.8^\circ}{\pi} \\ &\approx 209.703^\circ \end{aligned}$$

$$\begin{aligned} \text{e) } -6.14 &= -6.14 \left(\frac{180^\circ}{\pi} \right) \\ &= -\frac{1105.2^\circ}{\pi} \\ &\approx -351.796^\circ \end{aligned}$$

$$\begin{aligned} \text{f) } -20 &= -20 \left(\frac{180^\circ}{\pi} \right) \\ &= -\frac{3600^\circ}{\pi} \\ &\approx -1145.916^\circ \end{aligned}$$

Section 4.1 Page 175

Question 6

a) An angle that measures 1 radian is in quadrant I.

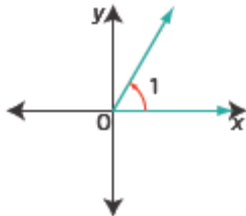

b) An angle that measures 225° is in quadrant II.

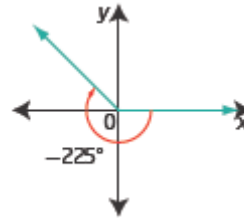

c) An angle that measures $\frac{17\pi}{6}$ is in quadrant II.

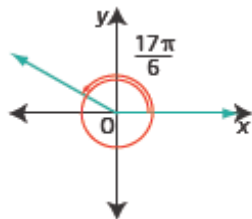

d) An angle that measures 650° is in quadrant IV.

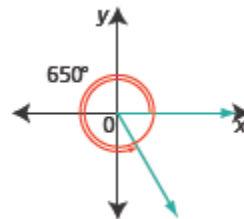

e) An angle that measures $-\frac{2\pi}{3}$ is in quadrant III.

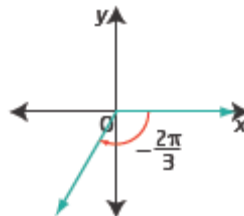

f) An angle that measures -42° is in quadrant IV.

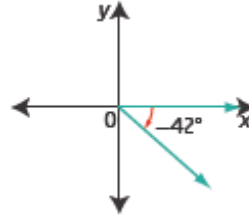

Section 4.1 Page 176 Question 7

a) $72^\circ + 360^\circ = 432^\circ$ $72^\circ - 360^\circ = -288^\circ$

For an angle of 72° , one positive coterminal angle is 432° and one negative coterminal angle is -288° .

b) $\frac{3\pi}{4} + 2\pi = \frac{11\pi}{4}$ $\frac{3\pi}{4} - 2\pi = -\frac{5\pi}{4}$

For an angle of $\frac{3\pi}{4}$, one positive coterminal angle is $\frac{11\pi}{4}$ and one negative coterminal angle is $-\frac{5\pi}{4}$.

c) $-120^\circ + 360^\circ = 240^\circ$ $-120^\circ - 360^\circ = -480^\circ$

For an angle of -120° , one positive coterminal angle is 240° and one negative coterminal angle is -480° .

d) $\frac{11\pi}{2} - 2\pi = \frac{7\pi}{2}$ $\frac{11\pi}{2} - 6\pi = -\frac{\pi}{2}$

For an angle of $\frac{11\pi}{2}$, one positive coterminal angle is $\frac{7\pi}{2}$ and one negative coterminal angle is $-\frac{\pi}{2}$.

e) $-205^\circ + 360^\circ = 155^\circ$ $-205^\circ - 360^\circ = -565^\circ$

For an angle of -205° , one positive coterminal angle is 155° and one negative coterminal angle is -565° .

f) $7.8 - 2\pi \approx 1.5$ $7.8 - 4\pi \approx -4.8$

For an angle of -7.8 , one positive coterminal angle is 1.5 and one negative coterminal angle is -4.8 .

Section 4.1 Page 176 Question 8

a) The angles $\frac{5\pi}{6}$ and $\frac{17\pi}{6}$ are coterminal because

$$\begin{aligned}\frac{5\pi}{6} + 2\pi &= \frac{5\pi}{6} + \frac{12\pi}{6} \\ &= \frac{17\pi}{6}\end{aligned}$$

b) The angles $\frac{5\pi}{2}$ and $\frac{17\pi}{6}$ are not coterminal because $\frac{5\pi}{2}$ is coterminal with $\frac{\pi}{2}$ which falls on the positive y-axis, while $\frac{17\pi}{6}$ is coterminal with $\frac{5\pi}{6}$, which is in quadrant II.

c) The angles 410° and -410° are not coterminal because 410° is coterminal with 50° and so is in quadrant I, while -410° is coterminal with 310° and is in quadrant IV.

d) The angles 227° and -493° are coterminal because -493° is coterminal with $-493^\circ + 2(360^\circ)$ which is 227° .

Section 4.1 Page 176 Question 9

a) The coterminal angles for 135° are $135^\circ \pm (360^\circ)n$, where n is any natural number.

b) The coterminal angles for $-\frac{\pi}{2}$ are $-\frac{\pi}{2} \pm 2\pi n$, where n is any natural number.

c) The coterminal angles for -200° are $-200^\circ \pm (360^\circ)n$, where n is any natural number.

d) The coterminal angles for 10 radians are $10 \pm 2\pi n$, where n is any natural number.

Section 4.1 Page 176 Question 10

Example: Choose -45° .

$$\begin{aligned}-45^\circ &= -45^\circ + 360^\circ \\ &= 315^\circ\end{aligned}$$

In general, all angles coterminal with -45° are given by $-45^\circ \pm (360^\circ)n$, where n is any natural number.

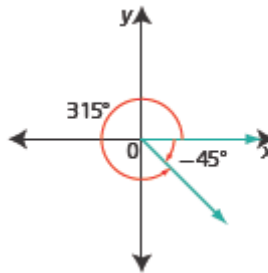

Section 4.1 Page 176 Question 11

a) $65^\circ + 360^\circ = 425^\circ$

In the domain $0^\circ \leq \theta < 720^\circ$, the angle 425° is coterminal with 65° .

b) $-40^\circ + 360^\circ = 320^\circ$

In the domain $-180^\circ \leq \theta < 360^\circ$, the angle 320° is coterminal with -40° .

c) $-40^\circ + 360^\circ = 320^\circ$ $-40^\circ - 360^\circ = -400^\circ$

$-40^\circ + 2(360^\circ) = 680^\circ$

In the domain $-720^\circ \leq \theta < 720^\circ$, the angles -400° , 320° , and 680° are coterminal with -40° .

d) $\frac{3\pi}{4} - 2\pi = -\frac{5\pi}{4}$

In the domain $-2\pi \leq \theta < 2\pi$, the angle $-\frac{5\pi}{4}$ is coterminal with $\frac{3\pi}{4}$.

e) $-\frac{11\pi}{6} - 2\pi = -\frac{23\pi}{6}$ $-\frac{11\pi}{6} + 2\pi = \frac{\pi}{6}$ $-\frac{11\pi}{6} + 4\pi = \frac{13\pi}{6}$

In the domain $-4\pi \leq \theta < 4\pi$, the angles $-\frac{23\pi}{6}$, $\frac{\pi}{6}$ and $\frac{13\pi}{6}$ are coterminal with $-\frac{11\pi}{6}$.

f) $\frac{7\pi}{3} - 2\pi = \frac{\pi}{3}$ $\frac{7\pi}{3} - 4\pi = -\frac{5\pi}{3}$

In the domain, $-2\pi \leq \theta < 4\pi$, the angles $\frac{\pi}{3}$ and $-\frac{5\pi}{3}$ are coterminal with $\frac{7\pi}{3}$.

g) $2.4 - 2\pi \approx -3.9$

In the domain $-2\pi \leq \theta < 2\pi$, the angle -3.9 is coterminal with 2.4 .

h) $-7.2 + 2\pi \approx -0.9$ $-7.2 + 4\pi \approx 5.4$ $-7.2 - 2\pi \approx -13.5$ (outside specified domain)

In the domain $-4\pi \leq \theta < 2\pi$, the angles -0.9 and 5.4 are coterminal with -7.2 .

Section 4.1 Page 176 Question 12

- a) Use a proportion with $r = 9.5$ and central angle 1.4 radians.

$$\frac{\text{arc length}}{\text{circumference}} = \frac{\text{central angle}}{\text{complete rotation}}$$

$$\frac{\text{arc length}}{2\pi(9.5)} = \frac{1.4}{2\pi}$$

$$\begin{aligned}\text{arc length} &= 1.4(9.5) \\ &= 13.3\end{aligned}$$

The arc length is 13.3 cm.

- b) Use the formula $a = \theta r$, with $r = 1.37$ and $\theta = 3.5$.

$$\begin{aligned}a &= 3.5(1.37) \\ &= 4.795\end{aligned}$$

The arc length is 4.80 m, to the nearest hundredth of a metre.

- c) Use a proportion with $r = 7$ and central angle 130° .

$$\frac{\text{arc length}}{\text{circumference}} = \frac{\text{central angle}}{\text{complete rotation}}$$

$$\frac{\text{arc length}}{2\pi(7)} = \frac{130}{360}$$

$$\begin{aligned}\text{arc length} &= \frac{13(14\pi)}{36} \\ &\approx 15.88\end{aligned}$$

The arc length is 15.88 cm, to the nearest hundredth of a centimetre.

- d) Use a proportion with $r = 6.25$ and central angle 282° .

$$\frac{\text{arc length}}{\text{circumference}} = \frac{\text{central angle}}{\text{complete rotation}}$$

$$\frac{\text{arc length}}{2\pi(6.25)} = \frac{282}{360}$$

$$\begin{aligned}\text{arc length} &= \frac{282(12.5\pi)}{360} \\ &\approx 30.76\end{aligned}$$

The arc length is 30.76 in., to the nearest hundredth of an inch.

Section 4.1 Page 176 Question 13

a) Use the formula $a = \theta r$, with $a = 9$ and $r = 4$.

$$9 = \theta(4)$$

$$\frac{9}{4} = \theta$$

$$2.25 = \theta$$

The central angle is 2.25 radians.

b) Use the formula $a = \theta r$, with $\theta = 1.22$ and $r = 9$.

$$a = 1.22(9)$$

$$= 10.98$$

The arc length is 10.98 ft.

c) Use the formula $a = \theta r$, with $a = 15$ and $\theta = 3.93$.

$$15 = 3.93r$$

$$\frac{15}{3.93} = r$$

$$3.82 \approx r$$

The radius is 3.82 cm, to the nearest hundredth of a centimetre.

d) Use a proportion with $r = 7$ and central angle 140° .

$$\frac{\text{arc length}}{\text{circumference}} = \frac{\text{central angle}}{\text{complete rotation}}$$

$$\frac{\text{arc length}}{2\pi(7)} = \frac{140}{360}$$

$$\text{arc length} = \frac{14(14\pi)}{36}$$

$$\approx 17.10$$

The arc length is 17.10 m, to the nearest hundredth of a metre.

Section 4.1 Page 176 Question 14

a) Use the formula $a = \theta r$, with $r = 5$ and $\theta = \frac{5\pi}{3}$.

$$a = \left(\frac{5\pi}{3}\right)5$$

$$= \frac{25\pi}{3}$$

$$\approx 26.18$$

The arc length of the sector watered is $\frac{25\pi}{3}$ m or 26.18 m, to the nearest tenth of a metre.

b) Use a proportion with $r = 5$ and central angle $\frac{5\pi}{3}$.

$$\frac{\text{area of sector}}{\text{area of circle}} = \frac{\text{central angle}}{\text{complete rotation}}$$

$$\frac{\text{area of sector}}{\pi(5)^2} = \frac{\frac{5\pi}{3}}{2\pi}$$

$$\text{area of sector} = \frac{5(25\pi)}{6}$$

The area of the sector watered is $\frac{125\pi}{6}$, or approximately 65.45 m².

c) The sprinkler makes one revolution every 15 s, so in 2 min it will make 8 revolutions. In 2 min the sprinkler will rotate through $8(2\pi)$ radians, which is 16π radians, or $8(360^\circ)$ which is 2880° .

Section 4.1 Page 177 Question 15

a) One revolution in 24 h is the same as:

$$\frac{360^\circ}{24} \text{ per hour, which is } 15^\circ/\text{h}; \text{ or } \pi \text{ radians in 12 h, which is } \frac{\pi}{12} \text{ radians/h}$$

b) $1000 \text{ rpm} = 1000(2\pi) \text{ radians/min}$

$$= \frac{1000(2\pi)}{60} \text{ radians/s}$$

The angular velocity of the motor is $\frac{100\pi}{3}$ radians per second.

c) 10 revolutions in 4 s is $\frac{10(360^\circ)}{4}$ or 900° per second.

In one minute, this is $60(900^\circ)$ or $54\,000^\circ$.

The angular velocity of the bicycle wheel is $54\,000^\circ/\text{min}$.

Section 4.1 Page 177 Question 16

a) Use the formula $a = \theta r$, with $a = 170$ and $r = 72$.

$$170 = \theta(72)$$

$$\frac{170}{72} = \theta$$

$$2.36 \approx \theta$$

The central angle of the cable swing is 2.36 radians, to the nearest hundredth of a radian.

$$\begin{aligned} \text{b) } 2.36 \text{ radians} &= 2.36 \left(\frac{180^\circ}{\pi} \right) \\ &\approx 135.3^\circ \end{aligned}$$

The measure of the central angle is 135.3° , to the nearest tenth of a degree.

Section 4.1 Page 177 Question 17

	Revolutions	Degrees	Radians
a)	1 rev	360°	2π
b)	0.75 rev	270°	$\frac{3\pi}{2}$ or 4.7
c)	0.4 rev	150°	$\frac{5\pi}{6}$
d)	-0.3 rev	-97.4°	-1.7
e)	-0.1 rev	-40°	$-\frac{2\pi}{9}$ or -0.7
f)	0.7 rev	252°	$\frac{7\pi}{5}$ or 4.4
g)	-3.25 rev	-1170°	$-\frac{13\pi}{2}$ or -20.4
h)	$\frac{23}{18}$ or 1.3 rev	460°	$\frac{23\pi}{9}$ or 8.0
i)	$-\frac{3}{16}$ or -0.2 rev	-67.5°	$-\frac{3\pi}{8}$

Section 4.1 Page 177 Question 18

Joran's answer includes the given angle, obtained when $n = 0$. Jasmine's answer is better as it excludes the actual given angle and just generates all positive and negative coterminal angles.

Section 4.1 Page 177 Question 19

a) $360^\circ = 400 \text{ grads}$

So, $1^\circ = \frac{400}{360} \text{ grads}$

$$\begin{aligned} \text{Then, } 50^\circ &= 50 \left(\frac{\overset{10}{\cancel{400}}}{\underset{9}{\cancel{360}}} \right) \\ &= \frac{500}{9} \\ &\approx 55.6 \text{ grads} \end{aligned}$$

b) Use the equivalence $360^\circ = 400 \text{ grads}$. To convert from degrees to gradians, multiply the number of degrees by $\frac{400}{360}$. To convert from gradians to degrees, multiply the number of gradians by $\frac{360}{400}$.

c) The gradian was developed in France along with the metric system. A right angle, or 90° is 100 gradians and so fractions of a right angle can be expressed in decimal form in gradians.

Section 4.1 Page 178 Question 20

a) The central angle is $62.45^\circ - 49.63^\circ$, or 12.82° .

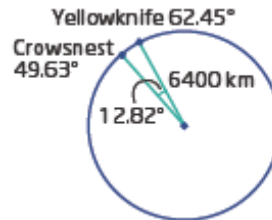

b) Use a proportion with $r = 6400$ and central angle 12.82° .

$$\frac{\text{arc length}}{\text{circumference}} = \frac{\text{central angle}}{\text{complete rotation}}$$

$$\frac{\text{arc length}}{2\pi(6400)} = \frac{12.82}{360}$$

$$\begin{aligned} \text{arc length} &= \frac{12.82(1280\pi)}{36} \\ &\approx 1432.01 \end{aligned}$$

The distance between Yellowknife and Crowsnest Pass is 1432.01 km, to the nearest hundredth of a kilometre.

c) Example: Bowden and Aidrie are both approximately 114° W. Bowden is at 51.93° N and Aidrie is at 51.29° N.

So, the central angle is $51.93^\circ - 51.29^\circ$ or 0.64° .

Use a proportion with $r = 6400$ and central angle 0.64° .

$$\frac{\text{arc length}}{\text{circumference}} = \frac{\text{central angle}}{\text{complete rotation}}$$

$$\frac{\text{arc length}}{2\pi(6400)} = \frac{0.64}{360}$$

$$\begin{aligned}\text{arc length} &= \frac{0.64(1280\pi)}{36} \\ &\approx 71.49\end{aligned}$$

The distance between Bowden and Aidrie is 71.49 km, to the nearest hundredth of a kilometre.

Section 4.1 Page 178 Question 21

$$\begin{aligned}\text{a) } 133.284 \text{ km/h} &= \frac{133.284(1000)}{60} \text{ m/min} \\ &= 2221.4 \text{ m/min}\end{aligned}$$

Sam Whittingham's speed, in the 200-m flying start race, was 2221.4 m/min.

b) The bicycle wheel circumference is $\pi(0.6)$ m.

So, the number of wheel turns in 2221.4 m is $\frac{2221.4}{0.6\pi}$.

Then, the angular speed of the wheel is $\left(\frac{2221.4}{0.6\pi}\right)(2\pi)$ or approximately 7404.7 radians per minute.

Section 4.1 Page 178 Question 22

Speed of the water wheel is 15 rpm or $15(3\pi)$ m/min.

Convert the speed to kilometres per hour.

$$\begin{aligned}15(3\pi) \text{ m/min} &= \frac{15(3\pi)(60)}{1000} \text{ km/h} \\ &\approx 8.5 \text{ km/h}\end{aligned}$$

The speed of the water wheel is approximately 8.5 km/h.

Section 4.1 Page 178 Question 23

In one revolution about the sun, Earth travels $93\,000\,000(2\pi)$ miles.

Convert $93\,000\,000(2\pi)$ miles in 365 days to a speed in miles per hour.

This is $\frac{93\,000\,000(2\pi)}{365(24)}$ miles per hour.

The speed of Earth is approximately 66 705.05 mph.

Section 4.1 Page 178 Question 24

$$\begin{aligned} \text{a) } 69.375^\circ &= 69^\circ + \left(\frac{375}{1000}\right)60' \\ &= 69^\circ + 22.5' \\ &= 69^\circ 22' 30'' \end{aligned}$$

$$\begin{aligned} \text{b) i) } 40.875^\circ &= 40^\circ + \left(\frac{875}{1000}\right)60' & \text{ii) } 100.126^\circ &= 100^\circ + \left(\frac{126}{1000}\right)60' \\ &= 40^\circ + 52.5' & &= 100^\circ + 7.56' \\ &= 40^\circ 52' 30'' & &= 100^\circ 7' + \left(\frac{56}{100}\right)60'' \\ & & &= 100^\circ 7' 33.6'' \end{aligned}$$

$$\begin{aligned} \text{iii) } 14.565^\circ &= 14^\circ + \left(\frac{565}{1000}\right)60' & \text{iv) } 80.385 &= 80^\circ + \left(\frac{385}{1000}\right)60' \\ &= 14^\circ + 33.9' & &= 80^\circ + 23.1' \\ &= 14^\circ 33' + \left(\frac{9}{10}\right)60'' & &= 80^\circ 23' + \left(\frac{1}{10}\right)60'' \\ &= 14^\circ 33' 54'' & &= 80^\circ 23' 6'' \end{aligned}$$

Section 4.1 Page 179 Question 25

$$\begin{aligned} \text{a) } 69^\circ 22' 30'' &= 69^\circ 22' + \left(\frac{30}{60}\right)' \\ &= 69^\circ 22.5' \\ &= 69^\circ + \left(\frac{22.5}{60}\right)' \\ &= 69.375^\circ \end{aligned}$$

$$\begin{aligned} \text{b) i) } 45^\circ 30' 30'' &= 45^\circ 30' + \left(\frac{30}{60}\right)' \\ &= 45^\circ 30.5' \\ &= 45^\circ + \left(\frac{30.5}{60}\right)' \\ &\approx 45.508^\circ \end{aligned}$$

$$\begin{aligned} \text{ii) } 72^\circ 15' 45'' &= 72^\circ 15' + \left(\frac{45}{60}\right)' \\ &= 72^\circ 15.75' \\ &= 72^\circ + \left(\frac{15.75}{60}\right)' \\ &\approx 72.263^\circ \end{aligned}$$

$$\begin{aligned} \text{iii) } 105^\circ 40' 15'' &= 105^\circ 40' + \left(\frac{15}{60}\right)' \\ &= 105^\circ 40.25' \\ &= 105^\circ + \left(\frac{40.25}{60}\right)' \\ &\approx 105.671^\circ \end{aligned}$$

$$\begin{aligned} \text{iv) } 28^\circ 10' &= 28^\circ 10' \\ &= 28^\circ + \left(\frac{10}{60}\right)' \\ &\approx 28.167^\circ \end{aligned}$$

Section 4.1 Page 179 Question 26

First, write an expression for the area of the sector.

Use a proportion with central angle θ .

$$\begin{aligned} \frac{\text{area of sector}}{\text{area of circle}} &= \frac{\theta}{2\pi} \\ \text{area of sector} &= \frac{\theta(\pi r^2)}{2\pi} \\ &= \frac{\theta r^2}{2} \end{aligned}$$

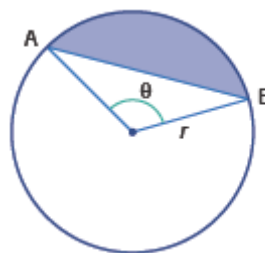

Next, derive an expression for the area of the triangle.

The perpendicular height from the centre of the circle to AB will bisect the triangle into two congruent right triangles. The height will be $r \cos \frac{\theta}{2}$. The length AB will be

$$2r \sin \frac{\theta}{2}.$$

$$\begin{aligned} \text{Area of triangle} &= \frac{(2r \sin \frac{\theta}{2})(r \cos \frac{\theta}{2})}{2} \\ &= r^2 \sin \frac{\theta}{2} \cos \frac{\theta}{2} \\ &= \frac{1}{2} r^2 \sin \theta \end{aligned}$$

Then, area of shaded segment = area of sector – area of triangle

$$\begin{aligned} &= \frac{\theta r^2}{2} - \frac{1}{2} r^2 \sin \theta \\ &= \frac{r^2}{2} (\theta - \sin \theta) \end{aligned}$$

Section 4.1 Page 179 Question 27

a) At 4:00, the minute hand is at 12 and the hour hand is at 4.

$$\begin{aligned} \text{Angle} &= \frac{4}{12}(360^\circ) \\ &= 120^\circ \end{aligned}$$

The angle between the hand of a clock at 4:00 is 120° .

b) At 4:10 the hour hand will have moved $\left(\frac{10}{60}\right)30^\circ$, or 5° past the 4. The minute hand will have rotated $\left(\frac{10}{60}\right)360^\circ$, or 60° from the 12. The angle between the hands at 4:10 is $120^\circ + 5^\circ - 60^\circ$, or 65° .

c) Example: The hands are at right angles to each other at 3:00 and at 9:00.

d) The hand are at right angles twice between 4:00 and 5:00.

Represent the time as $4 + x$, where x is the number of minutes past the hour.

Then, the hour hand will have moved $\left(\frac{x}{60}\right)30^\circ$. The minute hand will have rotated

$\left(\frac{x}{60}\right)360^\circ$. The angle between the hands is 90° when

$$120^\circ + \left(\frac{x}{60}\right)30^\circ - \left(\frac{x}{60}\right)360^\circ = 90^\circ$$

Solve the equation:

$$\begin{aligned} 120 + \frac{x}{2} - 6x &= 90 \\ 60 &= 11x \\ x &= \frac{60}{11} \\ x &\approx 5.5 \end{aligned}$$

To the nearest minute, the hands will be at right angles to each other at 4:05.

There is another such time, when the minute hand is beyond the hour hand.

In this case, the minute hand is ahead of the hour hand, so the equation to solve is

$$6x - 120 - \frac{x}{2} = 90$$

$$\frac{11x}{2} = 210$$

$$11x = 420$$

$$x \approx 38$$

To the nearest minute, the hands will be at right angles to each other at 4:38.

e) As shown in part d) above, one time occurs shortly after 4:05.

Section 4.1 Page 179 Question C1

One revolution is 2π radians, which is approximately 6.28 radians. So, 6 radians is a little less than 360° .

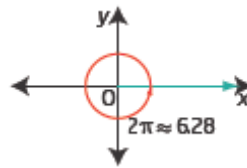

Section 4.1 Page 179 Question C2

One degree is $\frac{1}{360}$ th of a complete revolution; so it is a very small angle. On the other hand, 1 radian is an amount of rotation that cuts off an arc with length equal to the radius. It is a little less than $\frac{1}{6}$ th of a complete revolution.

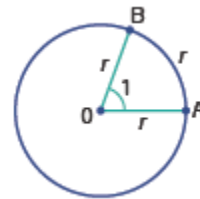

Section 4.1 Page 179 Question C3

a) $860^\circ - 720^\circ = 140^\circ$
 The reference angle is $180^\circ - 140^\circ$, or 40° .
 An expression for all coterminal angles is $140^\circ \pm 360^\circ n$, $n \in \mathbb{N}$.

b) $(-7 + 4\pi)$ rad ≈ 5.566 rad
 The reference angle is $2\pi - 5.566$ rad, or 0.72 rad, to the nearest hundredth. An expression for all coterminal angles is $0.72 \pm 2\pi n$, $n \in \mathbb{N}$.

Section 4.1 Page 179 Question C4

a)

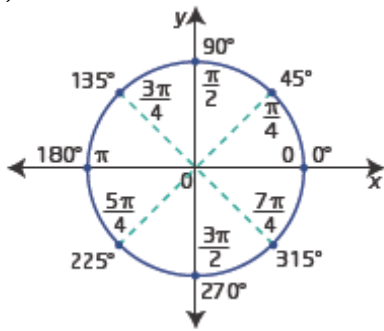

b)

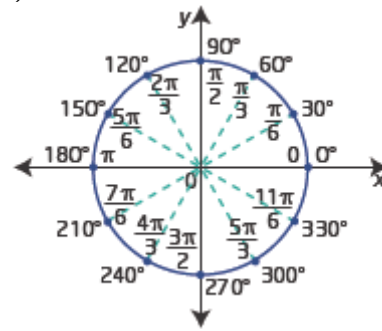

Section 4.1 Page 179 Question C5

a) $x = 3$

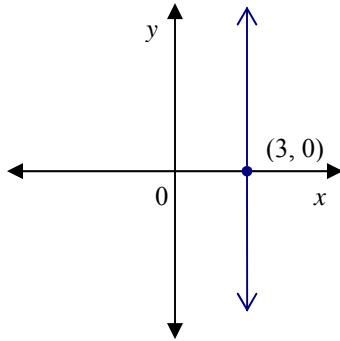

b) $y = x - 3$

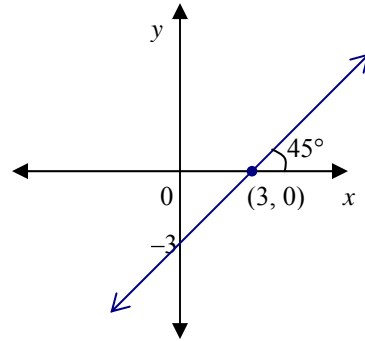

Section 4.2 The Unit Circle

Section 4.2 Page 186 Question 1

a) In $x^2 + y^2 = r^2$, substitute $r = 4$.
 $x^2 + y^2 = 16$

b) In $x^2 + y^2 = r^2$, substitute $r = 3$.
 $x^2 + y^2 = 9$

c) In $x^2 + y^2 = r^2$, substitute $r = 12$.
 $x^2 + y^2 = 144$

d) In $x^2 + y^2 = r^2$, substitute $r = 2.6$.
 $x^2 + y^2 = 2.6^2$
 $x^2 + y^2 = 6.76$

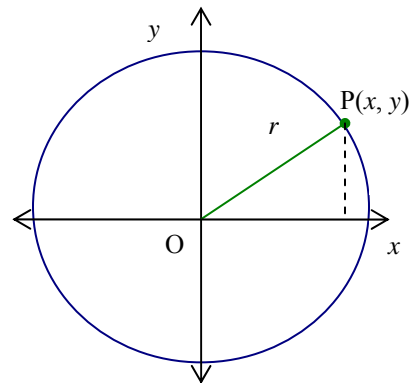

Section 4.2 Page 186 Question 2

A point is on the unit circle if $x^2 + y^2 = 1$.

a) For $\left(-\frac{3}{4}, \frac{1}{4}\right)$,

$$\begin{aligned} \left(-\frac{3}{4}\right)^2 + \left(\frac{1}{4}\right)^2 &= \frac{9}{16} + \frac{1}{16} \\ &= \frac{10}{16} \text{ or } \frac{5}{8} \\ &\neq 1 \end{aligned}$$

Therefore, the point $\left(-\frac{3}{4}, \frac{1}{4}\right)$ is not on the unit circle.

b) For $\left(\frac{\sqrt{5}}{8}, \frac{7}{8}\right)$,

$$\begin{aligned} \left(\frac{\sqrt{5}}{8}\right)^2 + \left(\frac{7}{8}\right)^2 &= \frac{5}{64} + \frac{49}{64} \\ &= \frac{54}{64} \neq 1 \end{aligned}$$

Therefore, the point $\left(\frac{\sqrt{5}}{8}, \frac{7}{8}\right)$ is not on the unit circle.

c) For $\left(-\frac{5}{13}, \frac{12}{13}\right)$,

$$\begin{aligned} \left(-\frac{5}{13}\right)^2 + \left(\frac{12}{13}\right)^2 &= \frac{25}{169} + \frac{144}{169} \\ &= \frac{169}{169} \\ &= 1 \end{aligned}$$

Therefore, the point $\left(-\frac{5}{13}, \frac{12}{13}\right)$ is on the unit circle.

d) For $\left(\frac{4}{5}, -\frac{3}{5}\right)$,

$$\begin{aligned} \left(\frac{4}{5}\right)^2 + \left(-\frac{3}{5}\right)^2 &= \frac{16}{25} + \frac{9}{25} \\ &= \frac{25}{25} \\ &= 1 \end{aligned}$$

Therefore, the point $\left(\frac{4}{5}, -\frac{3}{5}\right)$ is on the unit circle.

e) For $\left(-\frac{\sqrt{3}}{2}, -\frac{1}{2}\right)$,

$$\begin{aligned} \left(-\frac{\sqrt{3}}{2}\right)^2 + \left(-\frac{1}{2}\right)^2 &= \frac{3}{4} + \frac{1}{4} \\ &= \frac{4}{4} \\ &= 1 \end{aligned}$$

Therefore, the point $\left(-\frac{\sqrt{3}}{2}, -\frac{1}{2}\right)$ is on the unit circle.

f) For $\left(\frac{\sqrt{7}}{4}, \frac{3}{4}\right)$,

$$\begin{aligned} \left(\frac{\sqrt{7}}{4}\right)^2 + \left(\frac{3}{4}\right)^2 &= \frac{7}{16} + \frac{9}{16} \\ &= \frac{16}{16} \\ &= 1 \end{aligned}$$

Therefore, the point $\left(\frac{\sqrt{7}}{4}, \frac{3}{4}\right)$ is on the unit circle.

$$\text{a) } \left(\frac{1}{4}\right)^2 + y^2 = 1$$

$$y^2 = 1 - \frac{1}{16}$$

$$y^2 = \frac{15}{16}$$

$$y = \pm \frac{\sqrt{15}}{4}$$

$$\text{In quadrant I, } y = \frac{\sqrt{15}}{4}.$$

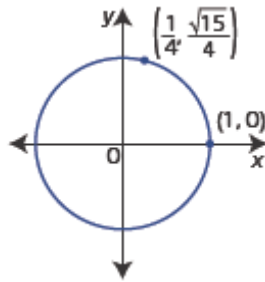

$$\text{b) } x^2 + \left(\frac{2}{3}\right)^2 = 1$$

$$x^2 = 1 - \frac{4}{9}$$

$$x = \pm \frac{\sqrt{5}}{3}$$

$$\text{In quadrant II, } x = -\frac{\sqrt{5}}{3}.$$

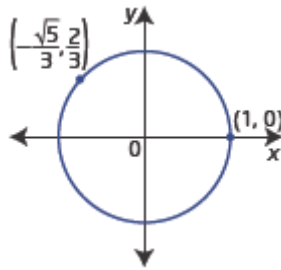

$$\text{c) } \left(-\frac{7}{8}\right)^2 + y^2 = 1$$

$$y^2 = 1 - \frac{49}{64}$$

$$y^2 = \frac{15}{64}$$

$$y = \pm \frac{\sqrt{15}}{8}$$

$$\text{In quadrant III, } y = -\frac{\sqrt{15}}{8}.$$

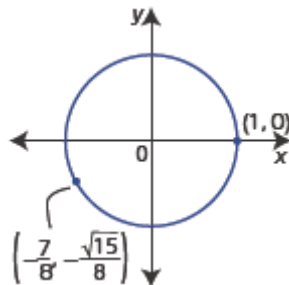

$$\text{d) } x^2 + \left(-\frac{5}{7}\right)^2 = 1$$

$$x^2 = 1 - \frac{25}{49}$$

$$x^2 = \frac{24}{49}$$

$$x = \pm \frac{\sqrt{24}}{7}$$

In quadrant IV, $x = \frac{\sqrt{24}}{7}$ or $\frac{2\sqrt{6}}{7}$.

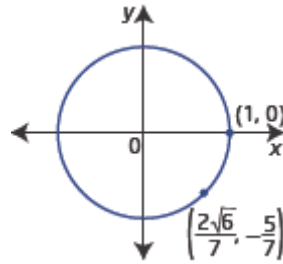

$$\text{e) } x^2 + \left(\frac{1}{3}\right)^2 = 1$$

$$x^2 = 1 - \frac{1}{9}$$

$$x^2 = \frac{8}{9}$$

$$x = \pm \frac{\sqrt{8}}{3}$$

For $x < 0$, $x = -\frac{\sqrt{8}}{3}$ or $-\frac{2\sqrt{2}}{3}$.

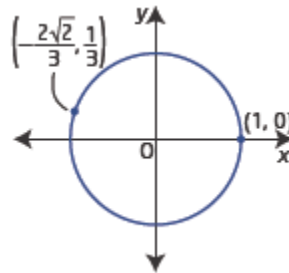

$$\text{f) } \left(\frac{12}{13}\right)^2 + y^2 = 1$$

$$y^2 = 1 - \frac{144}{169}$$

$$y^2 = \frac{25}{169}$$

$$y = \pm \frac{5}{13}$$

The point is not in quadrant I. Since it has a positive x -value, the point must be in quadrant IV

with $y = -\frac{5}{13}$.

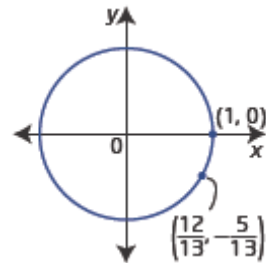

Section 4.2 Page 187 Question 4

a) A rotation of π radians takes the terminal arm of the angle on to the x -axis to the left of the origin.

So, $P(\pi) = (-1, 0)$.

b) A rotation of $-\frac{\pi}{2}$ radians takes the terminal arm of the angle onto the y-axis below the origin.

$$\text{So, } P\left(-\frac{\pi}{2}\right) = (0, -1).$$

c) A rotation of $\frac{\pi}{3}$ radians takes the terminal arm of the angle into the first quadrant as shown.

$$\text{So, } P\left(\frac{\pi}{3}\right) = \left(\frac{1}{2}, \frac{\sqrt{3}}{2}\right).$$

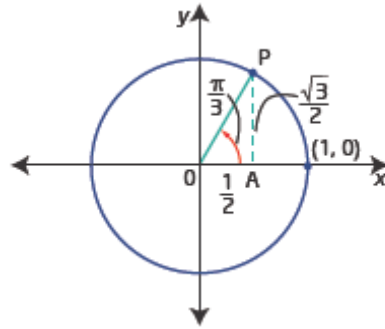

d) A rotation of $-\frac{\pi}{6}$ radians takes the terminal arm of the angle into quadrant IV as shown.

$$\text{So, } P\left(-\frac{\pi}{6}\right) = \left(\frac{\sqrt{3}}{2}, -\frac{1}{2}\right).$$

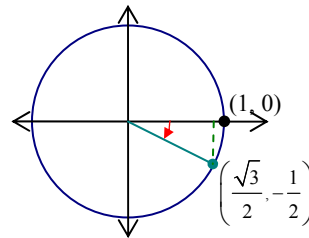

e) A rotation of $\frac{3\pi}{4}$ radians takes the terminal arm of the angle into the second quadrant as shown.

$$\text{So, } P\left(\frac{3\pi}{4}\right) = \left(-\frac{\sqrt{2}}{2}, \frac{\sqrt{2}}{2}\right).$$

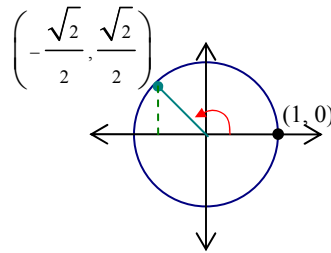

f) A rotation of $-\frac{7\pi}{4}$ radians takes the terminal arm of the angle into the first quadrant and is coterminal with $\frac{\pi}{4}$.

$$\text{So, } P\left(-\frac{7\pi}{4}\right) = \left(\frac{\sqrt{2}}{2}, \frac{\sqrt{2}}{2}\right).$$

g) A rotation of 4π is two complete turns and is coterminal with 0 radians.
So, $P(4\pi) = (1, 0)$.

h) A rotation of $\frac{5\pi}{2}$ radians is one complete turn plus one-half turn and takes the terminal arm of the angle onto the y -axis above the origin.

$$\text{So, } P\left(\frac{5\pi}{2}\right) = (0, 1).$$

i) A rotation of $\frac{5\pi}{6}$ radians takes the terminal arm of the angle into quadrant II as shown.

$$\text{So, } P\left(-\frac{\pi}{6}\right) = \left(-\frac{\sqrt{3}}{2}, \frac{1}{2}\right).$$

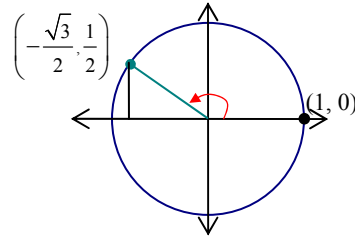

j) A rotation of $-\frac{4\pi}{3}$ radians takes the terminal arm of the angle into quadrant II, with reference angle $\frac{\pi}{3}$ as shown.

$$\text{So, } P\left(-\frac{4\pi}{3}\right) = \left(-\frac{1}{2}, \frac{\sqrt{3}}{2}\right).$$

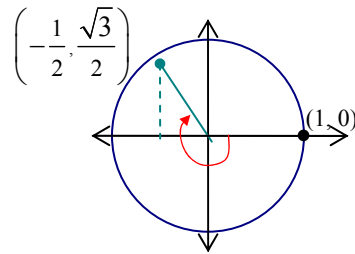

Section 4.2 Page 187 Question 5

a) $(0, -1)$ is on the y -axis, below the origin, so $\theta = \frac{3\pi}{2}$.

b) $(1, 0)$ is on the x -axis, to the right of the origin, so $\theta = 0$.

c) $\left(\frac{\sqrt{2}}{2}, \frac{\sqrt{2}}{2}\right)$ is in quadrant I, and since x and y are equal the measure of the central angle is $\frac{\pi}{4}$.

d) $\left(-\frac{1}{\sqrt{2}}, \frac{1}{\sqrt{2}}\right)$ is in quadrant II, and since x and y have equal length, the measure of the reference angle is $\frac{\pi}{4}$. In quadrant II, $\theta = \frac{3\pi}{4}$.

e) $\left(\frac{1}{2}, \frac{\sqrt{3}}{2}\right)$ is in quadrant I and $\theta = \frac{\pi}{3}$
as shown.

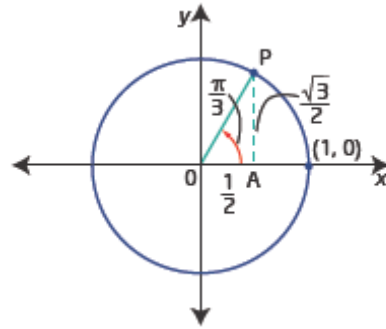

f) $\left(\frac{1}{2}, -\frac{\sqrt{3}}{2}\right)$ is in quadrant IV, and so $\theta = 2\pi - \frac{\pi}{3}$, or $\frac{5\pi}{3}$.

g) $\left(-\frac{\sqrt{3}}{2}, \frac{1}{2}\right)$ is in quadrant II as shown
and $\theta = \frac{5\pi}{6}$.

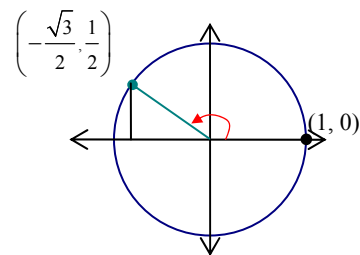

h) $\left(-\frac{\sqrt{3}}{2}, -\frac{1}{2}\right)$ is similar to part g), except the terminal arm is in quadrant III.
So, $\theta = \frac{7\pi}{6}$.

i) $\left(-\frac{\sqrt{2}}{2}, -\frac{\sqrt{2}}{2}\right)$ is in quadrant III, and since x and y are equal the measure of the central angle is $\pi + \frac{\pi}{4}$. So, $\theta = \frac{5\pi}{4}$.

j) $(-1, 0)$ is on the x -axis, to the left of the origin. So, $\theta = \pi$.

Section 4.2 Page 187 Question 6

If $P(\theta) = \left(-\frac{\sqrt{3}}{2}, \frac{1}{2}\right)$, then θ is in quadrant II as shown. One positive measure for θ is $\frac{5\pi}{6}$ and a coterminal negative angle is $\frac{5\pi}{6} - 2\pi$, or $-\frac{7\pi}{6}$.

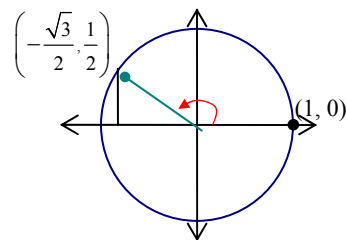

Section 4.2 Page 187 Question 7

a) Example: Choose $\theta = \frac{\pi}{3}$, then

$$\theta + \pi = \frac{\pi}{3} + \pi, \text{ or } \frac{4\pi}{3}.$$

$$P\left(\frac{\pi}{3}\right) = \left(\frac{1}{2}, \frac{\sqrt{3}}{2}\right) \text{ and}$$

$$P\left(\frac{4\pi}{3}\right) = \left(-\frac{1}{2}, -\frac{\sqrt{3}}{2}\right)$$

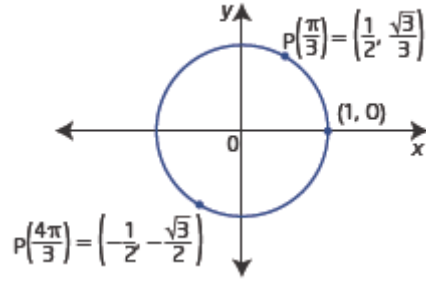

b) Example: Choose $\theta = \frac{3\pi}{4}$, then

$$\theta + \pi = \frac{3\pi}{4} + \pi, \text{ or } \frac{7\pi}{4}.$$

$$P\left(\frac{3\pi}{4}\right) = \left(-\frac{1}{\sqrt{2}}, \frac{1}{\sqrt{2}}\right), \text{ or } \left(-\frac{\sqrt{2}}{2}, \frac{\sqrt{2}}{2}\right)$$

and

$$P\left(\frac{7\pi}{4}\right) = \left(\frac{1}{\sqrt{2}}, -\frac{1}{\sqrt{2}}\right), \text{ or } \left(\frac{\sqrt{2}}{2}, -\frac{\sqrt{2}}{2}\right)$$

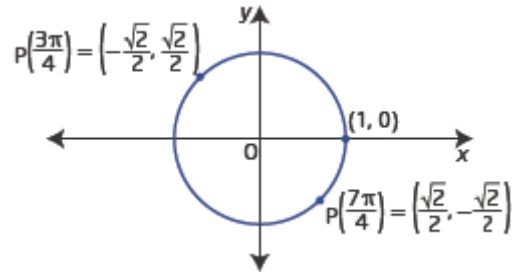

Section 4.2 Page 187 Question 8

Point	Step 2: $+\frac{1}{4}$ turn	Step 3: $-\frac{1}{4}$ turn	Step 4: Description	Diagram
$P(0) = (1, 0)$	$P\left(\frac{\pi}{2}\right)$ $= (0, 1)$	$P\left(-\frac{\pi}{2}\right)$ $= (0, -1)$	x- and y-values change places and take appropriate signs for the new quadrant	
$P\left(\frac{\pi}{3}\right)$ $= \left(\frac{1}{2}, \frac{\sqrt{3}}{2}\right)$	$P\left(\frac{\pi}{3} + \frac{\pi}{2}\right)$ $= P\left(\frac{5\pi}{6}\right)$ $= \left(-\frac{\sqrt{3}}{2}, \frac{1}{2}\right)$	$P\left(\frac{\pi}{3} - \frac{\pi}{2}\right)$ $= P\left(-\frac{\pi}{6}\right)$ $= \left(\frac{\sqrt{3}}{2}, \frac{1}{2}\right)$	x- and y-values change places and take appropriate signs for the new quadrant	

$P\left(\frac{5\pi}{3}\right)$ $= \left(\frac{1}{2}, -\frac{\sqrt{3}}{2}\right)$	$P\left(\frac{5\pi}{3} + \frac{\pi}{2}\right)$ $= P\left(\frac{\pi}{6}\right)$ $= \left(\frac{\sqrt{3}}{2}, \frac{1}{2}\right)$	$P\left(\frac{5\pi}{3} - \frac{\pi}{2}\right)$ $= P\left(\frac{7\pi}{6}\right)$ $= \left(-\frac{\sqrt{3}}{2}, -\frac{1}{2}\right)$	x - and y -values change places and take appropriate signs for the new quadrant	
--	---	--	--	--

Step 4: Concluding diagram.

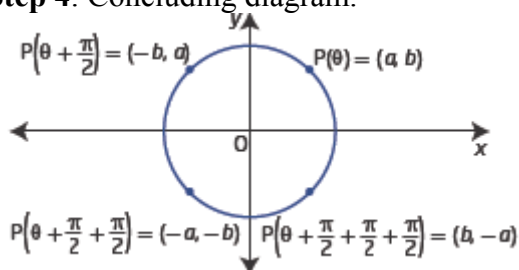

Section 4.2 Page 188 Question 9

a) The diagram shows a unit circle: $x^2 + y^2 = 1$.

b) C is related to B by a 90° rotation, so as shown in the previous question, the coordinates switch and the signs are adjusted. In quadrant I, both coordinates are positive. So the coordinates of B are $\left(\frac{\sqrt{5}}{3}, \frac{2}{3}\right)$.

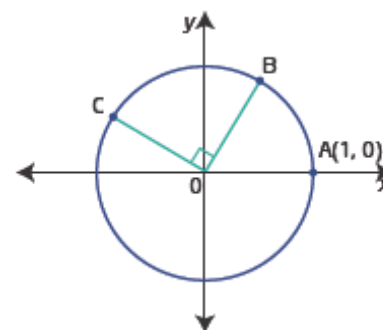

c) $\widehat{AC} = \widehat{AB} + \frac{\pi}{2}$

$$\widehat{AC} = \theta + \frac{\pi}{2}$$

d) If $P(\theta) = B$, then $P\left(\theta - \frac{\pi}{2}\right)$ is related by a rotation of $\frac{\pi}{2}$ clockwise, which puts it in quadrant IV.

e) The maximum value for the x -coordinates or the y -coordinates is 1. The minimum value for the x -coordinates or the y -coordinates is -1 .

Section 4.2 Page 188 Question 10

a) Mya is correct, because in quadrant I the x -coordinates start at 1 for an angle of 0° and decrease to a minimum of 0 for an angle of 90° .

b) Check Mya's answer by substituting $x = 0.807$ and $y = 0.348\ 751$ into the equation for the unit circle, $x^2 + y^2 = 1$. If the sum of the squares on the left side is not equal to 1, then Mya has made an error and her calculation needs checking. Observe that Mya forgot to take the square root.

$$\begin{aligned} \text{Left Side} &= (0.807)^2 + (0.348\ 751)^2 \\ &= 0.772\ 876\ 26 \\ &\neq 1 \end{aligned}$$

Recalculate: when $x = 0.807$

$$\begin{aligned} (0.807)^2 + y^2 &= 1 \\ y^2 &= 1 - (0.807)^2 \\ y &= \sqrt{1 - (0.807)^2} \\ y &\approx 0.590\ 551 \end{aligned}$$

c) Substitute $y = 0.2571$ in $x^2 + y^2 = 1$

$$\begin{aligned} x^2 + (0.2571)^2 &= 1 \\ x^2 &= 1 - (0.2571)^2 \\ x &= \sqrt{1 - (0.2571)^2} \\ x &\approx 0.9664 \end{aligned}$$

Section 4.2 Page 188 Question 11

a)

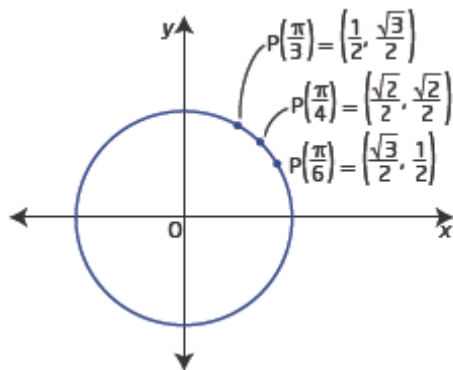

b) The denominators of the coordinates are all 2.

c) The numerators of the x -coordinates are decreasing as $P(\theta)$ increases, while the y -coordinates are increasing. This makes sense, in the quadrant I, because the terminal arm is getting closer to the y -axis as the angle increases. At $P\left(\frac{\pi}{4}\right)$ the x -coordinate and the y -coordinate are the same.

d) Square roots are derived from the special right triangles with acute angles $\frac{\pi}{4}$, $\frac{\pi}{4}$, and

$$\frac{\pi}{3}, \frac{\pi}{6}.$$

e) Example. Remember the patterns of side ratios for the special right triangles and that for angles less than $\frac{\pi}{4}$, the x -coordinate is greater than the y -coordinate.

Section 4.2 Page 188 Question 12

a) The interval $-2\pi \leq \theta < 4\pi$ represents three rotations around the unit circle: one complete clockwise rotation starting at 0 and two complete counterclockwise rotations. For every point on the unit circle there will be three coterminal angles in this interval.

b) If $P(\theta) = \left(-\frac{1}{2}, \frac{\sqrt{3}}{2}\right)$, then θ is in quadrant II.

In the interval $-2\pi \leq \theta < 0$, $\theta = -\frac{4\pi}{3}$.

In the interval $0 \leq \theta < 2\pi$, $\theta = \frac{2\pi}{3}$.

In the interval $2\pi \leq \theta < 4\pi$,
 $\theta = 2\pi + \frac{2\pi}{3}$, or $\frac{8\pi}{3}$.

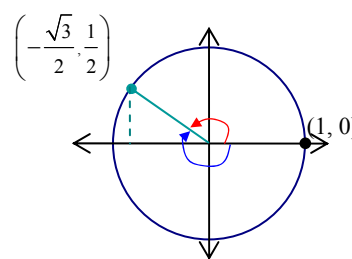

c) The terminal arm of the three angles is in the same position on the unit circle and all three angles have the same reference angle. The angles are “coterminal”.

Section 4.2 Page 188 Question 13

a) If $P(\theta) = \left(-\frac{1}{3}, -\frac{2\sqrt{2}}{3}\right)$, then θ is an

angle with terminal arm in quadrant III. The location of P, at the intersection of the terminal arm and the unit circle, is

given by $x = -\frac{1}{3}$ and $y = -\frac{2\sqrt{2}}{3}$.

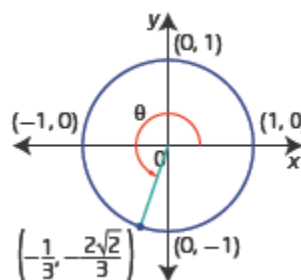

b) θ terminates in quadrant III.

c) $P\left(\theta + \frac{\pi}{2}\right)$ will be in quadrant IV and for a rotation of $+\frac{\pi}{2}$ the coordinates of P from part a) switch and the signs are adjusted for quadrant IV.

$$P\left(\theta + \frac{\pi}{2}\right) = \left(\frac{2\sqrt{2}}{3}, -\frac{1}{3}\right)$$

d) $P\left(\theta - \frac{\pi}{2}\right)$ will be in quadrant II and for a rotation of $-\frac{\pi}{2}$ the coordinates of P from part a) switch and the signs are adjusted for quadrant II.

$$P\left(\theta - \frac{\pi}{2}\right) = \left(-\frac{2\sqrt{2}}{3}, \frac{1}{3}\right)$$

Section 4.2 Page 189 Question 14

π units is a length. On the unit circle it is the arc of an angle from $(1, 0)$ to $(-1, 0)$.

π square units is an area. It is the area of the unit circle because when $r = 1$ in $A = \pi r^2$ the area is $A = \pi(1)^2$, or π square units.

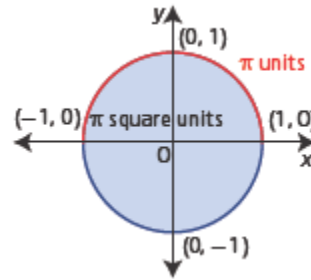

Section 4.2 Page 189 Question 15

a) Since ABCD is a rectangle, opposite sides are the same length. So, the coordinates of the other vertices are:

- B $(-a, b)$
- C $(-a, -b)$
- D $(a, -b)$

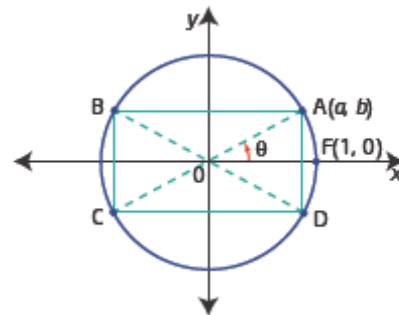

b) i) Since π is half a complete rotation, $\theta + \pi$ will have terminal arm OC. The angle will pass through C.

ii) Similarly, $-\pi$ is half a complete rotation, in the clockwise direction, so $\theta - \pi$ will have terminal arm OC. The angle will pass through C.

iii) $-\theta$ is the $\angle FOD$. A rotation of π from OD will have terminal arm OB. The angle $-\theta + \pi$ will pass through B.

iv) A rotation of $-\pi$ from OD will have terminal arm OB. The angle $-\theta - \pi$ will pass through B.

c) The answers would be the same because, since the angles are expressed in radians, arc FA is the same as θ .

Section 4.2 Page 189 Question 16

a) In a counterclockwise direction, arc SG is created by a rotation of $\frac{5\pi}{4}$.

The arc length of SG is $\frac{5\pi}{4}$.

b) $P\left(\frac{13\pi}{2}\right)$ represents a point on the unit circle

obtained by rotating an angle in standard position through 3 complete rotations plus half a rotation.

We know this because $\frac{13\pi}{2} = \frac{12\pi}{2} + \frac{\pi}{2}$, or $6\pi + \frac{\pi}{2}$

and 6π is 3 complete rotations of 2π each. The point on the unit circle corresponding to this amount of rotation is A.

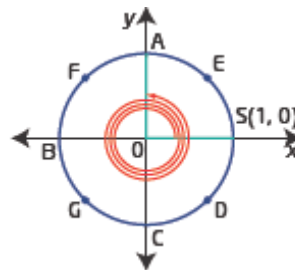

c) $P(5)$ is in quadrant IV. Since $P\left(\frac{3\pi}{2}\right)$ is approximately $P(4.71)$ and $P(2\pi)$ is approximately $P(6.28)$, so $P(5)$ is between C and D.

Section 4.2 Page 189 Question 17

a) $y = -3x$ ①

$x^2 + y^2 = 1$ ②

Substitute from ① into ②.

$x^2 + (-3x)^2 = 1$

$10x^2 = 1$

$x = \pm\sqrt{\frac{1}{10}}$

Substitute in ① to find the corresponding y -values

$y = -3\left(\pm\frac{1}{\sqrt{10}}\right)$

$y = \frac{3}{\sqrt{10}}$ or $y = -\frac{3}{\sqrt{10}}$

The points of intersection are $\left(\frac{1}{\sqrt{10}}, -\frac{3}{\sqrt{10}}\right)$, or $(0.1\sqrt{10}, -0.3\sqrt{10})$, and

$\left(-\frac{1}{\sqrt{10}}, \frac{3}{\sqrt{10}}\right)$, or $(-0.1\sqrt{10}, 0.3\sqrt{10})$.

b) The first point of intersection above is in quadrant IV and the second point is a rotation of π away, in quadrant II. Since the first coordinate is $\cos \theta$, the measure of reference angle θ is approximately 1.25 radians.

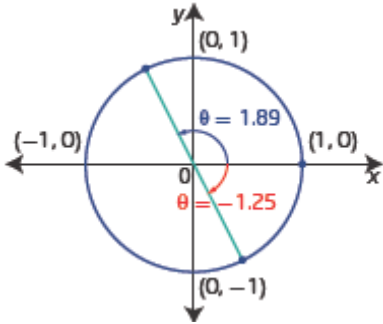

Section 4.2 Page 189 Question 18

a) First, use the Pythagorean theorem to determine the length of the hypotenuse OA.

$$OA^2 = 5^2 + 2^2$$

$$OA = \sqrt{29}$$

Next, compare sides of the similar right triangles.

$$\frac{x}{1} = \frac{5}{\sqrt{29}}$$

$$\frac{y}{1} = \frac{2}{\sqrt{29}}$$

$$x = \frac{5}{\sqrt{29}}$$

$$y = \frac{2}{\sqrt{29}}$$

The exact coordinates of $P(\theta)$ are $\left(\frac{5}{\sqrt{29}}, \frac{2}{\sqrt{29}}\right)$.

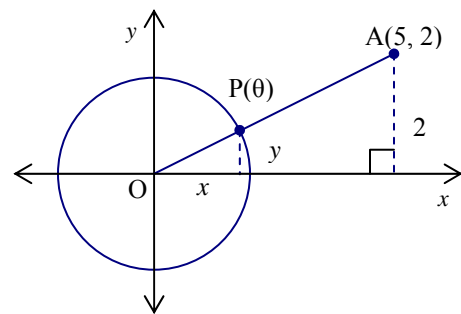

b) The radius of the larger circle passing through A is the length of OA found in part a). It is $\sqrt{29}$.

c) The equation for the larger circle passing through A is $x^2 + y^2 = 29$.

Section 4.2 Page 190 Question 19

Consider $P(\theta) = (x, y)$.

In the unit circle, the hypotenuse is 1.

Then, $\cos \theta = \frac{\text{adjacent}}{\text{hypotenuse}}$ and $\sin \theta = \frac{\text{opposite}}{\text{hypotenuse}}$

$$= \frac{x}{1}$$

$$= \frac{y}{1}$$

$$= x$$

$$= y$$

So, $P(\theta) = (\cos \theta, \sin \theta)$.

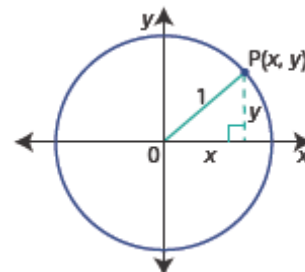

Section 4.2 Page 190 Question 20

a) $\left(\frac{\sqrt{2}}{2}, \frac{\sqrt{2}}{2}\right)$ are the coordinates of a point on the unit circle in quadrant I, describing a rotation of $\frac{\pi}{4}$. The equivalent polar coordinates are $\left(1, \frac{\pi}{4}\right)$.

b) $\left(-\frac{\sqrt{3}}{2}, -\frac{1}{3}\right)$ are the coordinates of a point on a circle in quadrant III.

First, determine the radius of the circle:

$$\left(-\frac{\sqrt{3}}{2}\right)^2 + \left(-\frac{1}{3}\right)^2 = r^2$$

$$\frac{3}{4} + \frac{1}{9} = r^2$$

$$\frac{31}{36} = r^2$$

$$r = \frac{\sqrt{31}}{6}$$

Next, determine the angle measure.

$$\tan \theta = \frac{y}{x}$$

$$= -\frac{1}{3} \div \left(-\frac{\sqrt{3}}{2}\right)$$

$$= -\frac{1}{3} \left(-\frac{2}{\sqrt{3}}\right)$$

$$= \frac{2}{2\sqrt{3}}$$

So, $\theta \approx 0.367$

This is the measure of the reference angle, so in quadrant III the angle is $\pi + 0.367$ or 3.509.

The equivalent polar coordinates are $\left(\frac{\sqrt{31}}{6}, 3.509\right)$.

c) (2, 2) are the coordinates of a point on a circle in quadrant I. Since $x = y$ this is a rotation of $\frac{\pi}{4}$.

Determine the radius:

$$2^2 + 2^2 = r^2$$

$$8 = r^2$$

$$r = 2\sqrt{2}$$

The equivalent polar coordinates are $\left(2\sqrt{2}, \frac{\pi}{4}\right)$.

d) $(4, -3)$ are the coordinates of a point on a circle in quadrant IV.

First, determine the radius:

$$4^2 + (-3)^2 = r^2$$

$$25 = r^2$$

$$r = 5$$

Next determine the angle measure.

$$\tan \theta = \frac{3}{4}$$

$$\theta \approx 0.644$$

This is the measure of the reference angle, so in quadrant IV the angle is $2\pi - 0.644$ or 5.640.

The equivalent polar coordinates are $(5, 5.640)$.

Section 4.2 Page 190 Question C1

a)

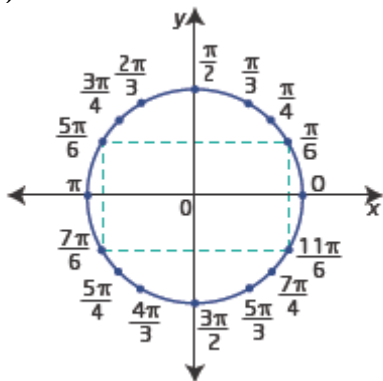

b)

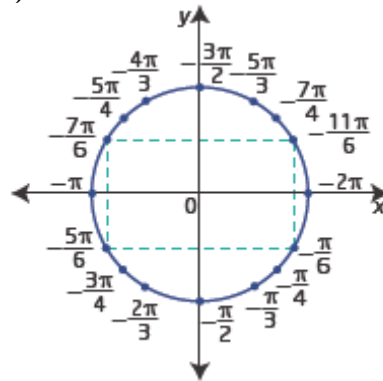

c) Using the special right triangle for $\frac{\pi}{6}$, the vertex in quadrant I has coordinates

$\left(\frac{\sqrt{3}}{2}, \frac{1}{2}\right)$. Then adjust the coordinates for the vertices of the rectangle in other quadrants.

In quadrant II, $P\left(\frac{5\pi}{6}\right) = \left(-\frac{\sqrt{3}}{2}, \frac{1}{2}\right)$.

In quadrant III, $P\left(\frac{7\pi}{6}\right) = \left(-\frac{\sqrt{3}}{2}, -\frac{1}{2}\right)$.

In quadrant IV, $P\left(\frac{11\pi}{6}\right) = \left(\frac{\sqrt{3}}{2}, -\frac{1}{2}\right)$.

d) Example: Divide the unit circle into eighths to mark off multiples of $\frac{\pi}{4}$. Use the ratio of sides of the special isosceles right triangle with hypotenuse 1 ($\frac{\sqrt{2}}{2} : \frac{\sqrt{2}}{2} : 1$) adjusting the signs of coordinates for each quadrant. Think of hours on a clock face to mark off multiples of $\frac{\pi}{6}$. Then, use the ratio of sides of the special right triangle with hypotenuse 1 ($\frac{\sqrt{3}}{2} : \frac{1}{2} : 1$) adjusting the signs of coordinates for each quadrant.

Section 4.2 Page 190 Question C2

a) Let n represent the measure of $\angle BOA$. Then, $\angle ABO = \angle BAO = 2n$.
Arc AB is the same as the measure of $\angle BAO$, in radians.
Use the angle sum of a triangle.

$$\begin{aligned} n + 2n + 2n &= \pi \\ 5n &= \pi \\ n &= \frac{\pi}{5} \end{aligned}$$

The measure of arc AB is $\frac{\pi}{5}$.

b) If $P(C) = P\left(B + \frac{\pi}{2}\right)$, then C must be in quadrant II.

The measure of arc AC, and of $\angle COA$, is

$$\frac{\pi}{5} + \frac{\pi}{2} = \frac{7\pi}{10}$$

Then in $\triangle OAC$,

$$\begin{aligned} \angle CAO + \angle ACO &= \pi - \frac{7\pi}{10} \\ &= \frac{3\pi}{10} \end{aligned}$$

Since $\angle CAO = \angle ACO$, $\angle CAO = \frac{3\pi}{20}$

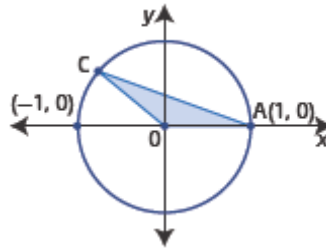

Section 4.2 Page 190 Question C3

a) $x^2 + y^2 = r^2$

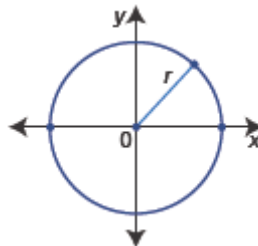

b) Example: If the centre of the circle is moved to (h, k) , then a new right triangle can be used to determine the equation. Its horizontal length will be $(x - h)$, and its vertical side will be $(y - k)$. Then, using the Pythagorean theorem $(x - h)^2 + (y - k)^2 = r^2$.

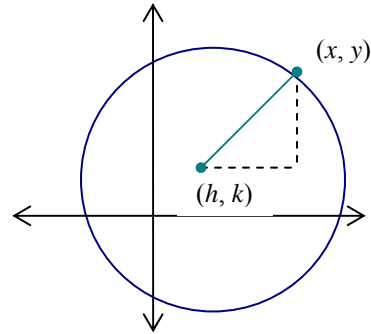

Section 4.2 Page 190 Question C4

a) Area of circle = $\pi(1^2)$
 Area of the square = 2^2

Percent of paper cut off = $\left(\frac{4 - \pi}{4}\right)100$
 $\approx 21.5\%$

b) Circumference : perimeter of square = $2\pi : 8$
 $= \pi : 4$

4.3 Trigonometric Ratios

Section 4.3 Page 201 Question 1

a) $\sin 45^\circ = \frac{y}{r}$
 $= \frac{\sqrt{2}}{2}$

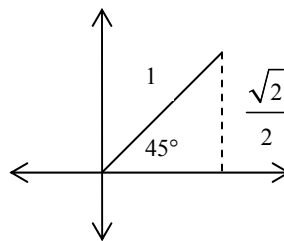

b) $\tan 30^\circ = \frac{x}{y} = \frac{\frac{1}{2}}{\frac{\sqrt{3}}{2}}$
 $= \frac{1}{\sqrt{3}}$ or $\frac{\sqrt{3}}{3}$

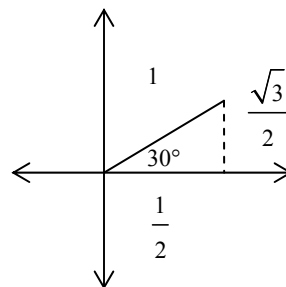

$$\begin{aligned} \text{c) } \cos \frac{3\pi}{4} &= \frac{x}{r} \\ &= \frac{-\frac{\sqrt{2}}{2}}{1} \\ &= -\frac{\sqrt{2}}{2} \end{aligned}$$

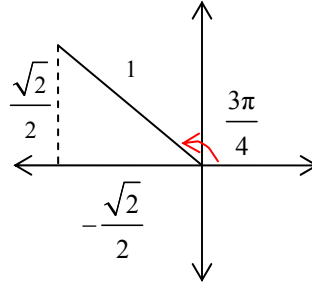

$$\begin{aligned} \text{d) } \cot \frac{7\pi}{6} &= \frac{y}{x} \\ &= \frac{-\frac{1}{2}}{-\frac{\sqrt{3}}{2}} \\ &= \sqrt{3} \end{aligned}$$

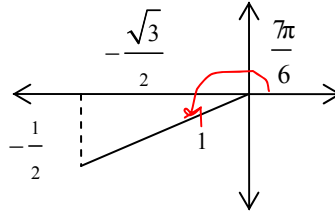

e) Refer to the diagram in part d), because $\frac{7\pi}{6} = 210^\circ$.

$$\begin{aligned} \csc 210^\circ &= \frac{r}{y} \\ &= \frac{1}{-\frac{1}{2}} \\ &= -2 \end{aligned}$$

$$\begin{aligned} \text{f) } \sec(-240^\circ) &= \frac{r}{x} \\ &= \frac{1}{-\frac{1}{2}} \\ &= -2 \end{aligned}$$

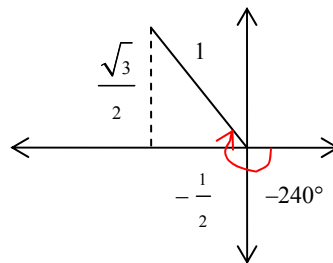

g) A point on the terminal arm of $\frac{3\pi}{2}$ is $(0, -1)$.

$$\begin{aligned} \text{Therefore, } \tan \frac{3\pi}{2} &= \frac{y}{x} \\ &= \frac{-1}{0} \\ &= \text{undefined} \end{aligned}$$

h) A point on the terminal arm of π is $(-1, 0)$.

$$\begin{aligned} \text{Therefore, } \sec \pi &= \frac{r}{x} \\ &= \frac{1}{-1} \\ &= -1 \end{aligned}$$

i) $\cot(-120^\circ) = \frac{x}{y}$

$$\begin{aligned} &= \frac{-\frac{1}{2}}{-\frac{\sqrt{3}}{2}} \\ &= \frac{1}{\sqrt{3}} \text{ or } \frac{\sqrt{3}}{3} \end{aligned}$$

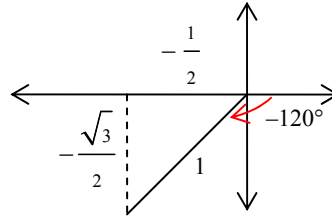

j) A rotation of 390° is coterminal with 30° .

$$\begin{aligned} \text{So, } \cos 390^\circ &= \cos 30^\circ \\ &= \frac{\sqrt{3}}{2} \end{aligned}$$

k) $\sin \frac{5\pi}{3} = \frac{y}{r}$

$$\begin{aligned} &= \frac{-\frac{\sqrt{3}}{2}}{1} \\ &= -\frac{\sqrt{3}}{2} \end{aligned}$$

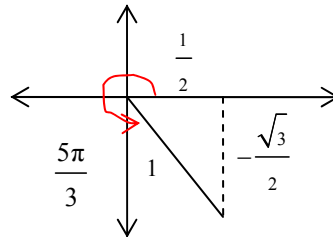

l) A rotation of 495° is coterminal with $495^\circ - 360^\circ$, or 135° .

Therefore, $\csc 495^\circ = \csc 135^\circ$

$$\begin{aligned} &= \frac{r}{y} \\ &= \frac{1}{\frac{\sqrt{2}}{2}} \\ &= \frac{2}{\sqrt{2}} \text{ or } \sqrt{2} \end{aligned}$$

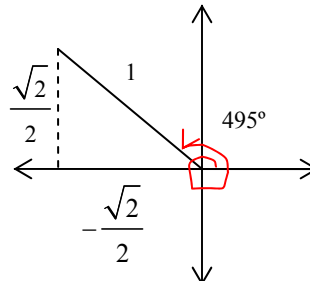

Section 4.3 Page 201 Question 2

Use a calculator. Verify that the sign is correct for the quadrant.

a) $\cos 47^\circ \approx 0.68$

b) $\cot 160^\circ = \frac{1}{\tan 160^\circ}$
 ≈ -2.75

c) $\sec 15^\circ = \frac{1}{\cos 15^\circ}$
 ≈ 1.04

d) $\csc 4.71 = \frac{1}{\sin 4.71}$
 ≈ -1.00

e) $\sin 5 \approx -0.96$

f) $\tan 0.94 \approx 1.37$

g) $\sin \frac{5\pi}{7} \approx 0.78$

h) $\tan 6.9 \approx 0.71$

i) $\cos 302^\circ \approx 0.53$

j) $\sin\left(-\frac{11\pi}{19}\right) \approx -0.97$

k) $\cot 6 = \frac{1}{\tan 6}$
 ≈ -3.44

l) $\sec(-270^\circ) = \frac{1}{\cos(-270^\circ)}$
 $= \frac{1}{0}$
 $= \text{undefined}$

Section 4.3 Page 202 Question 3

The diagram shows a memory aid for the ratios that are positive, i.e. greater than 0, in each quadrant.

a) $\cos \theta > 0$ in quadrants I and IV

b) $\tan \theta < 0$ in quadrants II and IV

c) $\sin \theta < 0$ in quadrants III and IV

d) $\sin \theta > 0$ in quadrants I and II, $\cot \theta < 0$ in quadrants II and IV, so both conditions are true in quadrant II.

e) $\cos \theta < 0$ in quadrants II and III, $\csc \theta > 0$ in quadrants I and II, so both conditions are true in quadrant II.

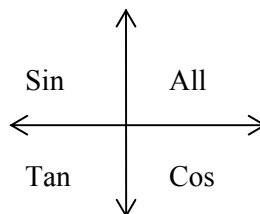

f) $\sec \theta > 0$ in quadrants I and IV, $\tan \theta > 0$ in quadrants I and III, so both conditions are true in quadrant I.

Section 4.3 Page 202 Question 4

a) $250^\circ = 180^\circ + 70^\circ$, so 250° is in quadrant III. In quadrant III, sine is negative. So, $\sin 250^\circ = -\sin 70^\circ$.

b) $290^\circ = 360^\circ - 70^\circ$, so 290° is in quadrant IV. In quadrant IV, tangent is negative. So, $\tan 290^\circ = -\tan 70^\circ$.

c) $135^\circ = 180^\circ - 45^\circ$, so 135° is in quadrant II. In quadrant II, cosine and secant are negative. So, $\sec 135^\circ = -\sec 45^\circ$.

d) 4 radians is in quadrant III and its reference angle is $4 - \pi$. In quadrant III, cosine is negative. So, $\cos 4 = -\cos(4 - \pi)$.

e) 3 radians is in quadrant II and its reference angle is $\pi - 3$. In quadrant II, sine and cosecant are positive. So, $\csc 3 = \csc(\pi - 3)$.

f) 4.95 radians is in quadrant III and its reference angle is $4.95 - \pi$. In quadrant III, tangent and cotangent are positive. So, $\cot 4.95 = \cot(4.95 - \pi)$.

Section 4.3 Page 202 Question 5

a) (3, 5) is in quadrant I.

$$\begin{aligned} \text{Use } \tan \theta &= \frac{y}{x} \\ &= \frac{5}{3} \end{aligned}$$

Then, the reference angle is $\theta \approx 1.03$.

A negative coterminal angle is $1.03 - 2\pi \approx -5.25$.

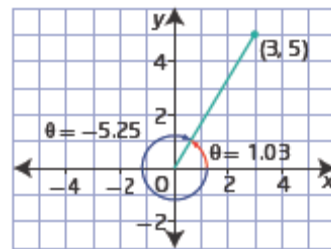

b) (-2, -1) is in quadrant III.

$$\begin{aligned} \text{Use } \tan \theta &= \frac{y}{x} \\ &= \frac{-1}{-2} \text{ or } 0.5 \end{aligned}$$

Then, the reference angle is $\theta \approx 0.4636\dots$

One positive angle, in quadrant III, is $\pi + \theta$ or approximately 3.61. A negative coterminal angle is $3.61 - 2\pi \approx -2.68$.

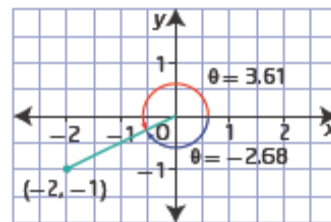

c) $(-3, 2)$ is in quadrant II.

$$\begin{aligned}\text{Use } \tan \theta &= \frac{y}{x} \\ &= \frac{2}{-3}\end{aligned}$$

Then, a reference angle is $\theta \approx 0.588\dots$

One positive angle, in quadrant II, is $\pi - \theta$ or approximately 2.55.

A negative coterminal angle is $-\pi - \theta$ or approximately -3.73 .

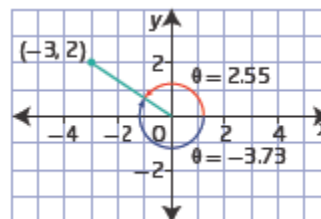

d) $(5, -2)$ is in quadrant IV.

$$\begin{aligned}\text{Use } \tan \theta &= \frac{y}{x} \\ &= \frac{-2}{5}\end{aligned}$$

Then, a reference angle is $\theta \approx -0.38$. This angle is in quadrant IV.

A positive coterminal angle is $2\pi + \theta$ or approximately 5.90.

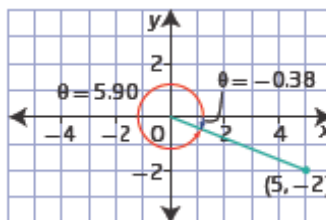

Section 4.3 Page 202 Question 6

a) $\cos \theta = \frac{x}{r}$. 300° is in quadrant IV, so the x -coordinate of a point on the terminal arm is positive. Therefore, $\cos 300^\circ$ is positive.

b) $\sin \theta = \frac{y}{r}$. 4 radians is in quadrant III, so the y -coordinate of a point on the terminal arm is negative. Therefore, $\sin 4$ is negative.

c) $\cot \theta = \frac{x}{y}$. 156° is in quadrant II, so the x -coordinate of a point on the terminal arm is negative and the y -coordinate is positive. Therefore, $\cot 156^\circ$ is negative.

d) $\csc \theta = \frac{r}{y}$. -235° is in quadrant II, so the y -coordinate of a point on the terminal arm is positive. Therefore, $\csc -235^\circ$ is positive.

e) $\tan \theta = \frac{y}{x} \cdot \frac{13\pi}{6}$ is coterminal with $\frac{\pi}{6}$ and is in quadrant I, so the x -coordinate of a point on the terminal arm is positive and the y -coordinate is positive. Therefore, $\tan \frac{13\pi}{6}$ is positive.

f) $\sec \theta = \frac{r}{x} \cdot \frac{17\pi}{3}$ is coterminal with $\frac{5\pi}{3}$ and is in quadrant IV, so the x -coordinate of a point on the terminal arm is positive. Therefore, $\sec \frac{17\pi}{3}$ is positive.

Section 4.3 Page 202 Question 7

a) $\sin^{-1} 0.2 \approx 0.2014$

This means that an angle of 0.2014 radians has a sine ratio of 0.2.

b) $\tan^{-1} 7 \approx 1.4289$

This means that an angle of 1.4289 radians has a tangent ratio of 7.

c) $\sec 450^\circ = \frac{1}{\cos 450^\circ}$ which is undefined because 450° is coterminal with 90° and $\cos 90^\circ = 0$.

d) $\cot(-180^\circ) = \frac{1}{\tan(-180^\circ)}$ which is undefined because (-180°) is coterminal with 180° and $\tan 180^\circ = 0$.

Section 4.3 Page 202 Question 8

a) Since $P(\theta) = \left(\frac{3}{5}, y\right)$ lies on the unit circle,

$$x^2 + y^2 = 1$$

$$\left(\frac{3}{5}\right)^2 + y^2 = 1$$

$$y^2 = 1 - \frac{9}{25}$$

$$y^2 = \frac{16}{25}$$

$$y = \pm \frac{4}{5}$$

For $P(\theta)$ to be in quadrant IV, y must be negative. So, $y = -\frac{4}{5}$.

$$\begin{aligned} \text{b) } \tan \theta &= \frac{y}{x} \\ &= \frac{-\frac{4}{5}}{\frac{3}{5}} \\ &= -\frac{4}{3} \end{aligned}$$

$$\begin{aligned} \text{c) } \csc \theta &= \frac{r}{y} \\ &= \frac{1}{-\frac{4}{5}} \\ &= -\frac{5}{4} \\ &= -1.25 \end{aligned}$$

Section 4.3 Page 202 Question 9

$$\begin{aligned} \text{a) } \cos 60^\circ + \sin 30^\circ &= \frac{1}{2} + \frac{1}{2} \\ &= 1 \end{aligned}$$

$$\begin{aligned} \text{b) } (\sec 45^\circ)^2 &= \frac{1}{(\cos 45^\circ)^2} \\ &= 1 \div \left(\frac{1}{\sqrt{2}} \right)^2 \\ &= 1 \div \frac{1}{2} \\ &= 2 \end{aligned}$$

$$\begin{aligned} \text{c) } \left(\cos \frac{5\pi}{3} \right) \left(\sec \frac{5\pi}{3} \right) \\ &= \left(\cos \frac{5\pi}{3} \right) \left(\frac{1}{\left(\cos \frac{5\pi}{3} \right)} \right) \\ &= 1 \end{aligned}$$

$$\begin{aligned} \text{d) } (\tan 60^\circ)^2 - (\sec 60^\circ)^2 \\ &= (\sqrt{3})^2 - \left(1 \div \left(\frac{1}{2} \right) \right)^2 \\ &= 3 - 4 \\ &= -1 \end{aligned}$$

$$\begin{aligned} \text{e) } \left(\cos \frac{7\pi}{4} \right)^2 + \left(\sin \frac{7\pi}{4} \right)^2 \\ &= \left(-\frac{1}{\sqrt{2}} \right)^2 + \left(\frac{1}{\sqrt{2}} \right)^2 \\ &= \frac{1}{2} + \frac{1}{2} \\ &= 1 \end{aligned}$$

$$\begin{aligned} \text{f) } \left(\cot \frac{5\pi}{6} \right)^2 &= 1 \div \left(\tan \frac{5\pi}{6} \right)^2 \\ &= 1 \div \left(-\frac{1}{\sqrt{3}} \right)^2 \\ &= 1 \div \frac{1}{3} \\ &= 3 \end{aligned}$$

Section 4.3 Page 202 Question 10

a) $\sin \theta = -\frac{1}{2}$, $0 \leq \theta < 2\pi$, means that θ is in quadrant III or IV. The reference angle is $\frac{\pi}{6}$.

In quadrant III, $\theta = \pi + \frac{\pi}{6}$, or $\frac{7\pi}{6}$.

In quadrant IV, $\theta = 2\pi - \frac{\pi}{6}$, or $\frac{11\pi}{6}$.

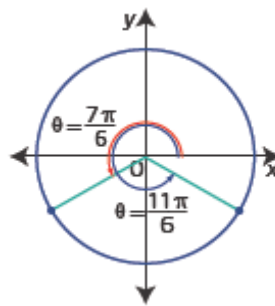

b) $\cot \theta = 1$, $-\pi \leq \theta < 2\pi$, means that θ is in quadrant I or III. The reference angle is $\frac{\pi}{4}$.

In quadrant I, $\theta = \frac{\pi}{4}$.

In quadrant III, for a positive rotation, $\theta = \pi + \frac{\pi}{4}$, or

$\frac{5\pi}{4}$. There is also a negative angle in the given domain

that falls in quadrant III; $\theta = -\pi + \frac{\pi}{4}$, or $-\frac{3\pi}{4}$.

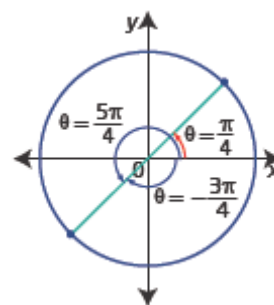

c) $\sec \theta = 2$, $-180^\circ \leq \theta < 90^\circ$; $\cos \theta = \frac{1}{2}$

means that θ is in quadrant I or IV. The reference angle is 60° .

In quadrant I, $\theta = 60^\circ$.

The negative rotation that is in quadrant IV is -60° .

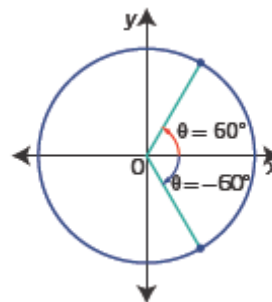

d) If $\cos^2 \theta = 1$, then $\cos \theta = \pm 1$.

In the domain $-360^\circ \leq \theta < 360^\circ$,

$\theta = 0^\circ, 180^\circ, -180^\circ, -360^\circ$.

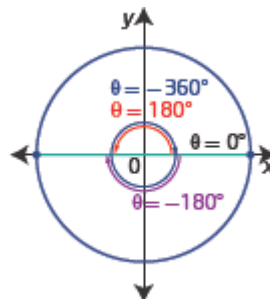

Section 4.3 Page 202 Question 11

a) $\cos \theta = 0.42$, gives a reference angle of $\theta \approx 1.14$.

Cosine is positive in quadrants I and IV.

So, in the domain $-\pi \leq \theta \leq \pi$,

$\theta \approx 1.14$ in quadrant I and

$\theta \approx -1.14$ in quadrant IV.

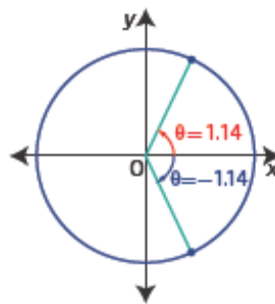

b) $\tan \theta = -4.87$, gives a value of $\theta \approx -1.37$.

Tangent is negative in quadrants II and

IV. So, in the domain $-\frac{\pi}{2} \leq \theta \leq \pi$,

In quadrant II, $\theta \approx \pi - 1.37$, so $\theta \approx 1.77$.

In quadrant IV, $\theta \approx -1.37$.

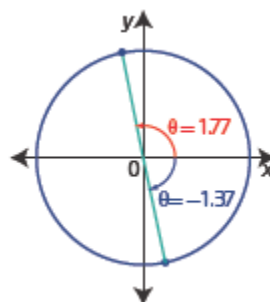

c) $\csc \theta = 4.87$, means $\sin \theta = \frac{1}{4.87}$, or $\sin \theta \approx 0.2053$.

This gives a value of $\theta \approx 11.85^\circ$.

Sine is positive in quadrants I and II. Consider the domain $-360^\circ \leq \theta < 180^\circ$.

For positive rotations: in quadrant I, $\theta \approx 11.85^\circ$ and in quadrant II, $\theta \approx 180^\circ - 11.85^\circ$, or 168.15° .

For negative rotations:

in quadrant I, $\theta \approx 11.85^\circ - 360^\circ$, or -348.15° , and

in quadrant II, $-180^\circ - 11.85^\circ$, or -191.85° .

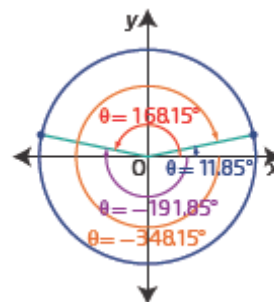

d) $\cot \theta = 1.5$, means $\tan \theta = \frac{1}{1.5}$, or $\tan \theta \approx 0.6666$.

This gives a value of $\theta \approx 33.69^\circ$.

Tangent, and cotangent, is positive in quadrants I and III. Consider the domain $-180^\circ \leq \theta < 360^\circ$.

For positive rotations: in quadrant I, $\theta \approx 33.69^\circ$ and in quadrant III, $\theta \approx 33.69^\circ + 180^\circ$ or 213.69° .

For negative rotations:

in quadrant III, $\theta \approx -180^\circ + 33.69^\circ$ or -146.31° .

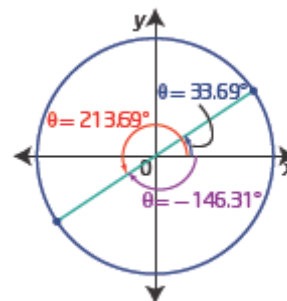

Section 4.3 Page 202 Question 12

a) Given $\sin \theta = \frac{3}{5}$, and $\frac{\pi}{2} < \theta < \pi$, then θ must

be in quadrant II, as shown. The x -coordinate must be -4 , since this is a 3-4-5 right triangle.

The other five trigonometric ratios are:

$$\begin{aligned} \cos \theta &= \frac{x}{r} & \tan \theta &= \frac{y}{x} \\ &= -\frac{4}{5} & &= -\frac{3}{4} \end{aligned}$$

$$\begin{aligned} \csc \theta &= \frac{r}{y} & \sec \theta &= \frac{r}{x} & \cot \theta &= \frac{x}{y} \\ &= \frac{5}{3} & &= -\frac{5}{4} & &= -\frac{4}{3} \end{aligned}$$

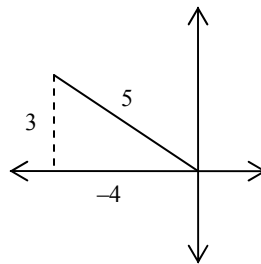

b) Given $\cos \theta = \frac{-2\sqrt{2}}{3}$, and $-\pi \leq \theta \leq \frac{3\pi}{2}$, then θ must be in quadrant II or III, with

$x = -2\sqrt{2}$ and $r = 3$, as shown.

Determine the y -coordinate.

$$x^2 + y^2 = r^2$$

$$x^2 + y^2 = r^2$$

$$(-2\sqrt{2})^2 + y^2 = 3^2$$

$$8 + y^2 = 9$$

$$y = \pm 1$$

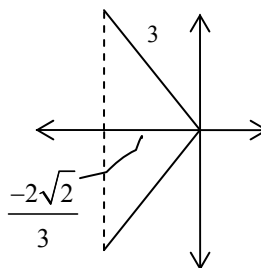

The other five trigonometric ratios are:

$$\begin{aligned} \sin \theta &= \frac{y}{r} & \tan \theta &= \frac{y}{x} \\ &= \pm \frac{1}{3} & &= \frac{\pm 1}{-2\sqrt{2}} \\ & & &= \pm \frac{\sqrt{2}}{4} \end{aligned}$$

$$\begin{aligned} \csc \theta &= \pm 3 & \sec \theta &= \frac{3}{-2\sqrt{2}} & \cot \theta &= \pm 2\sqrt{2} \\ & & &= -\frac{3\sqrt{2}}{4} & & \end{aligned}$$

c) Given $\tan \theta = \frac{2}{3}$ and $-360^\circ < \theta < 180^\circ$, θ is in quadrant I or III, as shown.

Determine the measure of r .

$$x^2 + y^2 = r^2$$

$$3^2 + 2^2 = r^2$$

$$13 = r^2$$

$$r = \sqrt{13}$$

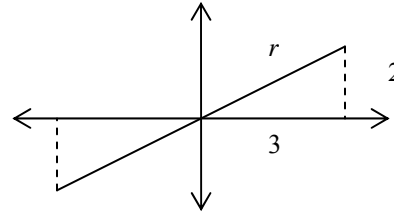

$$\sin \theta = \frac{y}{r} \quad \cos \theta = \frac{x}{r}$$

$$= \pm \frac{2}{\sqrt{13}} \quad = \pm \frac{3}{\sqrt{13}}$$

$$\csc \theta = \pm \frac{\sqrt{13}}{2} \quad \sec \theta = \pm \frac{\sqrt{13}}{3} \quad \cot \theta = \frac{3}{2}$$

d) Given $\sec \theta = \frac{4\sqrt{3}}{3}$, $\cos \theta = \frac{3}{4\sqrt{3}}$ or $\frac{\sqrt{3}}{4}$, and $-180^\circ \leq \theta \leq 180^\circ$, then θ is in quadrant

I or IV, with $x = 3$ and $r = 4\sqrt{3}$.

Determine the y -coordinate.

$$x^2 + y^2 = r^2$$

$$3^2 + y^2 = (4\sqrt{3})^2$$

$$9 + y^2 = 48$$

$$y = \pm\sqrt{39}$$

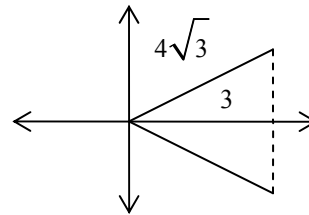

$$\sin \theta = \frac{y}{r}$$

$$= \pm \frac{\sqrt{39}}{4\sqrt{3}} \text{ or } \pm \frac{\sqrt{13}}{4}$$

$$\tan \theta = \frac{y}{x}$$

$$= \pm \frac{\sqrt{39}}{3}$$

$$\csc \theta = \pm \frac{4\sqrt{3}}{\sqrt{39}} \text{ or } \pm \frac{4\sqrt{13}}{13}$$

$$\cot \theta = \pm \frac{3}{\sqrt{39}} \text{ or } \pm \frac{\sqrt{39}}{13}$$

Section 4.3 Page 203 Question 13

Sketch the angle with point B(-2, -3) on its terminal arm. It is in quadrant III.

Use the Pythagorean theorem to calculate the measure of r in the right triangle with

$x = -2$ and $y = -3$. The measure of r is $\sqrt{13}$. The exact value of $\cos \theta$ can be determined as

$$\begin{aligned}\cos \theta &= \frac{x}{r} \\ &= \frac{-2}{\sqrt{13}} \text{ or } -\frac{2\sqrt{13}}{13}\end{aligned}$$

Section 4.3 Page 203 Question 14

a) $\frac{4900}{360} = 13\frac{220}{360}$, so the angle of 4900° is 13 complete revolutions plus 220° .

b) 220° puts the terminal arm in quadrant III.

c) Since 220° is 40° past 180° , the reference angle is 40° .

d) $\sin 4900^\circ \approx -0.643$, $\cos 4900^\circ \approx -0.766$, $\tan 4900^\circ \approx 0.839$,
 $\csc 4900^\circ \approx -1.556$, $\sec 4900^\circ \approx -1.305$, $\cot 4900^\circ \approx 1.192$

Section 4.3 Page 203 Question 15

a) $\sin(\cos^{-1} 0.6) = \frac{4}{5}$ or 0.8.

To evaluate $\cos^{-1} 0.6$ find an angle whose cosine is 0.6. In other words, $\cos \theta = \frac{x}{r} = \frac{6}{10}$

or $\frac{3}{5}$. This means θ can be determined using a 3-4-5 right triangle. Then, the sine of this

angle is $\sin \theta = \frac{y}{r} = \frac{4}{5}$.

b) $\cos(\sin^{-1} 0.6)$ is very similar to the result in part a), the only difference being the orientation of the 3-4-5 right triangle. So, the positive value of $\cos(\sin^{-1} 0.6)$ is 0.8.

Section 4.3 Page 203 Question 16

a) Jason is not correct. He used degree mode, when he should have chosen radian mode.

b) First choose radian mode. Determine $\cos\left(\frac{40\pi}{7}\right)$ and then use the reciprocal key to determine $\sec\left(\frac{40\pi}{7}\right)$. The correct answer is approximately 1.603 875 472.

Section 4.3 Page 203 Question 17

a) $\sin 1 \approx 0.841$, $\sin 2 \approx 0.909$, $\sin 3 \approx 0.141$, $\sin 4 \approx -0.757$
 So the values in increasing order are $\sin 4$, $\sin 3$, $\sin 1$, $\sin 2$.

b) 4 radians is in quadrant III, so $\sin 4$ is negative. 3 radians is very close to π , so close to 0, but positive. The value of $\pi/2$ is approximately 1.57, so $\sin 2$ is closer to the y-axis, where sine has value 1, than is $\sin 1$.

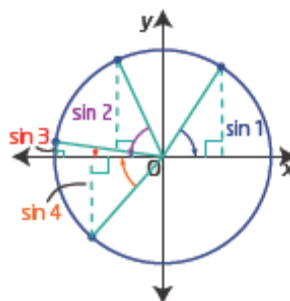

c) Cosine uses the x-coordinates which increase from left to right on the diagram. So the order is $\cos 3$, $\cos 4$, $\cos 2$, $\cos 1$.

Check: $\cos 3 \approx -0.999$, $\cos 4 \approx -0.654$, $\cos 2 \approx -0.416$, $\cos 1 \approx 0.540$

Section 4.3 Page 203 Question 18

a) As P moves around the wheel it can move from closest to the piston at $(1, 0)$ to furthest away at $(-1, 0)$. So the maximum distance that Q can move is 2 units.

b) At a speed of rotation is 1 radian/s, after 1 min the wheel will have travelled through 60 radians.

$$\frac{60}{2\pi} \approx 9.55$$

The wheel will have made 9 complete turns plus 0.55 of the next turn. This will put P in quadrant III at an angle of rotation of $(0.55)2\pi$ or approximately 3.451 33 radians.

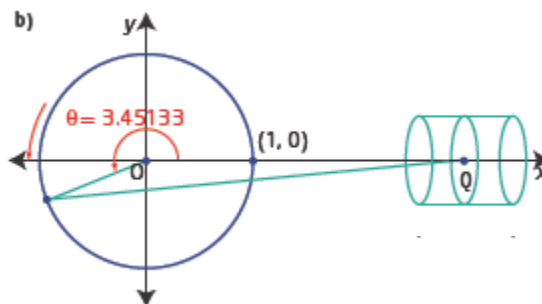

c) After 1 s, P will have moved 1 radian and pulled Q to the left a distance of $1 - \cos 1$, or 0.46 units, to the nearest hundredth.

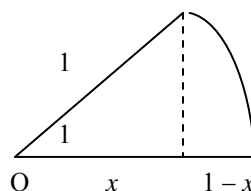

Section 4.3 Page 203 Question 19

a) $A(-3, 4)$, domain $0 < \theta \leq 4\pi$

Using the coordinates of A, $\tan \theta = \frac{4}{-3}$.

The reference angle is $\theta \approx 0.93$.

$A(-3, 4)$ is in quadrant II, so in the domain $0 < \theta \leq 4\pi$,
 $\theta \approx \pi - 0.93$, or 2.21, and $\theta \approx 2\pi + 2.21$, or 8.50.

b) $B(5, -1)$, $-360^\circ \leq \theta < 360^\circ$

Using the coordinates of B, $\tan \theta = \frac{-1}{5} = -0.2$.

The reference angle is $\theta \approx 11.31^\circ$.

$B(5, -1)$ is in quadrant IV, so in the domain $-360^\circ \leq \theta < 360^\circ$:

for negative rotations: $\theta \approx -11.31^\circ$

for positive rotations: $\theta \approx 360^\circ - 11.31^\circ$, or 348.69° .

c) $C(-2, -3)$, domain $-\frac{3\pi}{2} < \theta < \frac{7\pi}{2}$

Using the coordinates of C, $\tan \theta = \frac{-3}{-2} = 1.5$.

The reference angle is $\theta \approx 0.98$.

$C(-2, -3)$ is in quadrant III, so in the domain $-\frac{3\pi}{2} < \theta < \frac{7\pi}{2}$:

for negative rotations: $\theta \approx -\pi + 0.98$, or -2.16

for positive rotations: $\theta \approx \pi + 0.98$, or 4.12 and $3\pi + 0.98$, or 10.41

Section 4.3 Page 203 Question 20

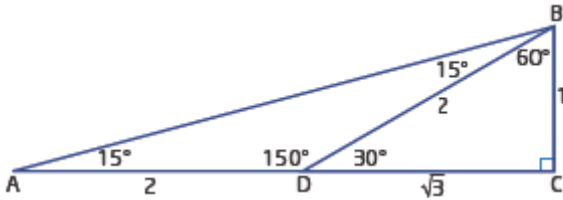

$\triangle BCD$ is a 30° - 60° - 90° triangle, so its sides have the proportions shown.

$\triangle ABD$ is isosceles, so $AD = BD = 2$ units.

Then in $\triangle ABC$,

$$\begin{aligned}\tan 15^\circ &= \frac{BC}{AC} \\ &= \frac{1}{\sqrt{3}+2}\end{aligned}$$

Section 4.3 Page 204 Question 21

Note: The text answers show a rationale using degrees. This solution provides an alternate, using radians.

The distance between $(0, 5)$ and $(5, 0)$ is $\frac{\pi}{2}$.

For the angle of rotation, θ , with $x = 2.5$,

$$\cos \theta = \frac{2.5}{5} = \frac{1}{2}. \text{ Therefore, } \theta = \frac{\pi}{3}.$$

So, moving from $(0, 5)$ to the point on the curve where $x = 2.5$, the angle of rotation is

$$-\frac{\pi}{6}. \text{ This angle has an arc length of } \frac{\pi}{6}$$

which is one-third of $\frac{\pi}{2}$.

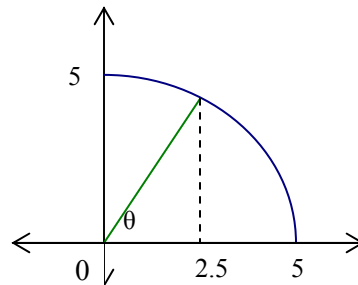

Section 4.3 Page 204 Question 22

a)

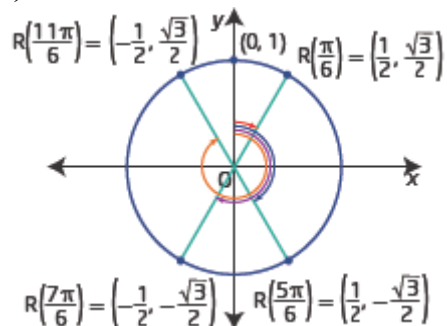

b) The new angle of rotation, $R\left(\frac{\pi}{6}\right)$, has the same terminal arm as the angle in standard position $P\left(\frac{\pi}{3}\right)$. So, $R\left(\frac{\pi}{6}\right) = \left(\frac{1}{2}, \frac{\sqrt{3}}{2}\right)$. The new angle of rotation, $R\left(\frac{5\pi}{6}\right)$, has the same terminal arm as the angle in standard position $P\left(\frac{5\pi}{3}\right)$. So, $R\left(\frac{5\pi}{6}\right) = \left(\frac{1}{2}, -\frac{\sqrt{3}}{2}\right)$.

c) The angles in the new system are related to angles in standard position by determining which quadrant the terminal arm is in and then determining the positive rotation to reach that terminal arm.

$$R\left(\frac{\pi}{6}\right) = \left(\frac{1}{2}, \frac{\sqrt{3}}{2}\right), R\left(\frac{5\pi}{6}\right) = \left(\frac{1}{2}, -\frac{\sqrt{3}}{2}\right), R\left(\frac{7\pi}{6}\right) = \left(-\frac{1}{2}, -\frac{\sqrt{3}}{2}\right), R\left(\frac{11\pi}{6}\right) = \left(-\frac{1}{2}, \frac{\sqrt{3}}{2}\right)$$

d) Bearings are measured clockwise from 0° . The new system is the same as bearings, except that bearings are measured in degrees.

Section 4.3 Page 204 Question 23

a) In $\triangle OBQ$, $\cos \theta = \frac{OB}{OQ} = \frac{1}{OQ}$.

Therefore, $\sec \theta = \frac{1}{\cos \theta} = OQ$.

b)

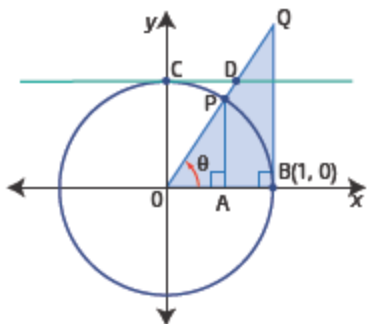

In $\triangle OCD$, $\angle ODC = \theta$ (alternate angles).

Then, $\sin \theta = \frac{OC}{OD} = \frac{1}{OD}$.

So, $\csc \theta = \frac{1}{\sin \theta} = OD$.

Similarly, $\cot \theta = CD$.

Section 4.3 Page 204 Question C1

a) Paula is correct, sine ratios are increasing in quadrant I.

Examples: $\sin 0 = 0$, $\sin \frac{\pi}{6} = 0.5$, $\sin \frac{\pi}{4} = \frac{\sqrt{2}}{2} \approx 0.707$, $\sin \frac{\pi}{3} = \frac{\sqrt{3}}{2} \approx 0.866$, $\sin \frac{\pi}{2} = 1$.

b) In quadrant II, sine is decreasing. In the unit circle, sine is given by the y-coordinate. As the end of the terminal arm moves past the y-axis, the y-coordinate decreases, from 1 to 0.

c) The sine ratio increases in quadrant IV. The y-coordinate has a minimum value of -1 at $\frac{3\pi}{2}$ and then its value increases to 0 at 2π .

Section 4.3 Page 204 Question C2

In this regular hexagon, the diagonals will intersect at the origin and each of the six angles at the center will be 60° .

The vertex in quadrant I is at 60° and has coordinates $\left(\frac{1}{2}, \frac{\sqrt{3}}{2}\right)$. The vertex in quadrant II is at 120° and has coordinates $\left(-\frac{1}{2}, \frac{\sqrt{3}}{2}\right)$. The next vertex is at 180° and has coordinates $(-1, 0)$. The vertex in quadrant III is at 240° and has coordinates $\left(-\frac{1}{2}, -\frac{\sqrt{3}}{2}\right)$. The vertex in quadrant IV is at 300° and has coordinates $\left(\frac{1}{2}, -\frac{\sqrt{3}}{2}\right)$.

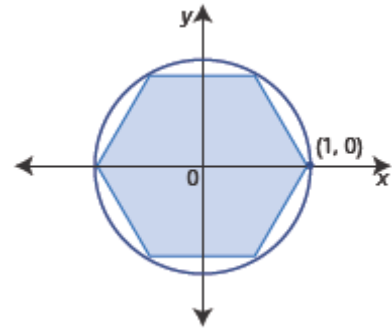

Section 4.3 Page 205 Question C3

a) If the coordinates of P are (x, y) then

$$\begin{aligned} \text{slope of } OP &= \frac{y}{x} \\ &= \tan \theta \end{aligned}$$

b) Yes, the formula is true in all four quadrants. In quadrant II and IV the slope will be negative, as expected.

c) An equation for the line OP, where O is the origin, is $y = (\tan \theta)x$.

d) For any line, the equation is $y = mx + b$, where m is the slope and b is the y-intercept. The slope can be defined in terms of a unit circle as $\tan \theta$, if the circle is not centred at the origin then a vertical translation of b units is needed. The equation is $y = (\tan \theta)x + b$.

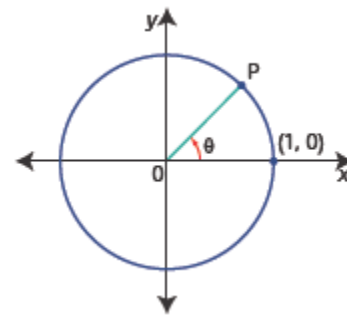

Section 4.3 Page 205 Question C4

$$\begin{aligned} \text{a) } \sin\left(\sin^{-1}\left(\frac{4}{5}\right)\right) &= \sin \theta \\ &= \frac{4}{5} \end{aligned}$$

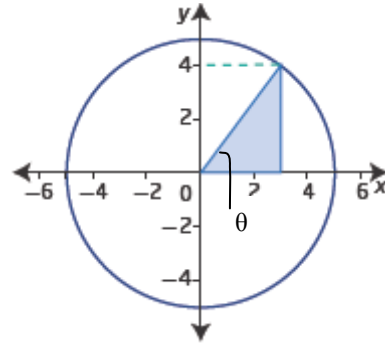

$$\begin{aligned} \text{b) } \cos\left(\tan^{-1}\left(\frac{4}{3}\right)\right) &= \cos \theta \\ &= \frac{3}{5} \end{aligned}$$

$$\begin{aligned} \text{c) } \csc\left(\cos^{-1}\left(-\frac{3}{5}\right)\right) &= \csc \theta \quad \text{Sine and cosecant are positive in quadrant II.} \\ &= \frac{1}{\sin \theta} \\ &= \frac{5}{4} \end{aligned}$$

$$\begin{aligned} \text{d) } \sin\left(\tan^{-1}\left(-\frac{4}{3}\right)\right) &= \sin(360^\circ - \theta) \quad \text{Sine is negative in quadrant IV.} \\ &= -\frac{4}{5} \end{aligned}$$

4.4 Introduction to Trigonometric Equations

Section 4.4 Page 211 Question 1

a) The given sine ratio is positive, so in the domain $0 \leq \theta < 2\pi$, there will be two solutions, one is quadrant I and one is quadrant II.

b) The given cosine ratio is positive. The domain $-2\pi \leq \theta < 2\pi$ is two complete rotations. There will be four solutions, two in quadrant I and two in quadrant IV.

c) The given tangent ratio is negative. This is true in quadrants II and IV. So, in the domain $-360^\circ \leq \theta \leq 180^\circ$ there will be three solutions, two in quadrant II and one is quadrant IV.

d) The given secant ratio, and thus the cosine ratio, is positive. This is true in quadrants I and IV. In the domain $-180^\circ \leq \theta < 180^\circ$ there will be two solutions, one in quadrant I and one in quadrant IV.

Section 4.4 Page 211 Question 2

a) For $\theta = \frac{\pi}{3}$, the general solution is $\theta = \frac{\pi}{3} + 2\pi n$, where $n \in \mathbb{I}$.

b) For $\theta = \frac{5\pi}{3}$, the general solution is $\theta = \frac{5\pi}{3} + 2\pi n$, where $n \in \mathbb{I}$.

Section 4.4 Page 211 Question 3

$$\begin{aligned} \text{a) } 2 \cos \theta - \sqrt{3} &= 0 \\ 2 \cos \theta &= \sqrt{3} \\ \cos \theta &= \frac{\sqrt{3}}{2} \\ \theta &= \frac{\pi}{6} \end{aligned}$$

Cosine is positive in quadrants I and IV. So, in the interval $0 \leq \theta < 2\pi$, $\theta = \frac{\pi}{6}$ and

$$\theta = \frac{11\pi}{6}.$$

b) $\csc \theta$ is undefined when $\sin \theta = 0$. So, in the domain $0^\circ \leq \theta < 360^\circ$, $\theta = 0^\circ$ and $\theta = 180^\circ$.

$$\begin{aligned} \text{c) } 5 - \tan^2 \theta &= 4 \\ 1 &= \tan^2 \theta \\ \tan \theta &= \pm 1 \end{aligned}$$

So, the reference angle for θ is 45° .

In the domain $-180^\circ \leq \theta \leq 360^\circ$, $\theta = -135^\circ, -45^\circ, 45^\circ, 135^\circ, 225^\circ$, and 315° .

$$\begin{aligned} \text{d) } \sec \theta + \sqrt{2} &= 0 \\ \sec \theta &= -\sqrt{2} \\ \cos \theta &= -\frac{1}{\sqrt{2}} \end{aligned}$$

The reference angle is $\frac{\pi}{4}$.

Cosine is negative in quadrants II and III.

So, in the domain $-\pi \leq \theta \leq \frac{3\pi}{2}$, $\theta = -\frac{3\pi}{4}$, $\frac{3\pi}{4}$, and $\frac{5\pi}{4}$.

Section 4.4 Page 211 Question 4

a) $\tan \theta = 4.36$

$$\theta = \tan^{-1} 4.36$$

$$\theta \approx 1.35$$

Tangent is positive in quadrants I and III.

So, in the domain $0 \leq \theta < 2\pi$, $\theta \approx 1.35$ and $\theta \approx \pi + 1.33$, or 4.49.

b) $\cos \theta = -0.19$

$$\theta = \cos^{-1} (-0.19)$$

$$\theta \approx 1.76$$

Cosine is negative in quadrants II and III.

So, in the domain $0 \leq \theta < 2\pi$, $\theta \approx 1.76$ and $\theta \approx 2\pi - 1.76$, or 4.52.

c) $\sin \theta = 0.91$

$$\theta = \sin^{-1} 0.91$$

$$\theta \approx 1.14$$

Sine is positive in quadrants I and II.

So, in the domain $0 \leq \theta < 2\pi$, $\theta \approx 1.14$ and $\theta \approx \pi - 1.14$, or 2.00

d) $\cot \theta = 12.3$

$$\theta = \tan^{-1} \left(\frac{1}{12.3} \right)$$

$$\theta \approx 0.08$$

Cotangent and tangent are positive in quadrants I and III.

So, in the domain $0 \leq \theta < 2\pi$, $\theta \approx 0.08$ and $\theta \approx \pi + 0.08$, or 3.22.

e) $\sec \theta = 2.77$

$$\theta = \cos^{-1} \left(\frac{1}{2.77} \right)$$

$$\theta \approx 1.20$$

Secant and cosine are positive in quadrants I and IV.

So, in the domain $0 \leq \theta < 2\pi$, $\theta \approx 1.20$ and $\theta \approx 2\pi - 1.20$, or 5.08.

f) $\csc \theta = -1.57$

$$\theta = \sin^{-1}\left(-\frac{1}{1.57}\right)$$

$$\theta \approx -0.69$$

Cosecant and sine are negative in quadrants III and VI.

So, in the domain $0 \leq \theta < 2\pi$, $\theta \approx \pi + 0.69$ or 3.83 and $\theta \approx 2\pi - 0.69$ or 5.59

Section 4.4 Page 211 Question 5

a) $3 \cos \theta - 1 = 4 \cos \theta$

$$-1 = \cos \theta$$

In the domain $0 \leq \theta < 2\pi$, $\theta = \pi$.

b) $\sqrt{3} \tan \theta + 1 = 0$

$$\tan \theta = -\frac{1}{\sqrt{3}}$$

Tangent is negative in quadrants II and IV.

In the domain $-\pi \leq \theta \leq 2\pi$, $\theta = -\frac{\pi}{6}$, $\theta = \frac{5\pi}{6}$, and $\theta = \frac{11\pi}{6}$.

c) $\sqrt{2} \sin x - 1 = 0$

$$\sin x = \frac{1}{\sqrt{2}}$$

Sine is positive in quadrants I and II.

In the domain $-360^\circ < \theta \leq 360^\circ$, $\theta = -315^\circ$, -225° , 45° , and 135° .

d) $3 \sin x - 5 = 5 \sin x - 4$

$$-1 = 2 \sin x$$

$$\sin x = -\frac{1}{2}$$

Sine is negative in quadrants III and IV.

In the domain $-360^\circ \leq x < 180^\circ$, $x = -150^\circ$ and -30° .

e) $3 \cot x + 1 = 2 + 4 \cot x$

$$-1 = \cot x$$

$$\tan x = -1$$

Tangent is negative in quadrants II and IV.

In the domain $-180^\circ < x < 360^\circ$, $x = -45^\circ$, 135° , and 315° .

f) $\sqrt{3} \sec \theta + 2 = 0$

$$\sec \theta = -\frac{2}{\sqrt{3}}$$

$$\cos \theta = -\frac{\sqrt{3}}{2}$$

Cosine is negative in quadrants II and III.

In the domain $-\pi \leq \theta \leq 3\pi$, $\theta = -\frac{5\pi}{6}$, $\frac{5\pi}{6}$, $\frac{7\pi}{6}$, and $\frac{17\pi}{6}$.

Section 4.4 Page 212 Question 6

	Domain	Interval
a)	$-2\pi \leq \theta \leq 2\pi$	$\theta \in [-2\pi, 2\pi]$
b)	$-\frac{\pi}{3} \leq \theta \leq \frac{7\pi}{3}$	$\theta \in \left[-\frac{\pi}{3}, \frac{7\pi}{3}\right]$
c)	$0^\circ \leq \theta \leq 270^\circ$	$\theta \in [0^\circ, 270^\circ]$
d)	$0 \leq \theta < \pi$	$\theta \in [0, \pi)$
e)	$0^\circ < \theta < 450^\circ$	$\theta \in (0^\circ, 450^\circ)$
f)	$-2\pi < \theta \leq 4\pi$	$\theta \in (-2\pi, 4\pi]$

Section 4.4 Page 212 Question 7

a) $2 \cos^2 \theta - 3 \cos \theta + 1 = 0$
 $(2 \cos \theta - 1)(\cos \theta - 1) = 0$
 $2 \cos \theta - 1 = 0$ or $\cos \theta - 1 = 0$
 $\cos \theta = \frac{1}{2}$ or $\cos \theta = 1$

In the domain $0 \leq \theta < 2\pi$,

$$\theta = \frac{\pi}{3}, \frac{5\pi}{3} \text{ or } \theta = 0$$

b) $\tan^2 \theta - \tan \theta - 2 = 0$
 $(\tan \theta - 2)(\tan \theta + 1) = 0$
 $\tan \theta - 2 = 0$ or $\tan \theta + 1 = 0$
 $\tan \theta = 2$ or $\tan \theta = -1$

In the domain $0^\circ \leq \theta < 360^\circ$,

$$\theta \approx 63.435^\circ, 243.435^\circ \text{ or } \theta = 135^\circ, 315^\circ$$

c) $\sin^2 \theta - \sin \theta = 0$

$$\sin \theta (\sin \theta - 1) = 0$$

$$\sin \theta = 0 \text{ or } \sin \theta - 1 = 0$$

$$\sin \theta = 1$$

In the domain $\theta \in [0, 2\pi)$,

$$\theta = 0, \pi \text{ or } \theta = \frac{\pi}{2}$$

d) $\sec^2 \theta - 2 \sec \theta - 3 = 0$

$$(\sec \theta - 3)(\sec \theta + 1) = 0$$

$$\sec \theta - 3 = 0 \text{ or } \sec \theta + 1 = 0$$

$$\sec \theta = 3 \text{ or } \sec \theta = -1$$

In the domain $\theta \in [-180^\circ, 180^\circ)$,

$$\theta \approx -70.529^\circ, 70.529^\circ \text{ or } \theta = -180^\circ$$

Section 4.4 Page 212 Question 8

Check for $\theta = 180^\circ$:

$$\text{Left Side} = 5 \cos^2 \theta$$

$$= 5 \cos^2 180^\circ$$

$$= 5(-1)^2$$

$$= 5$$

$$\text{Right Side} = -4 \cos \theta$$

$$= -4 \cos 180^\circ$$

$$= -4(-1)$$

$$= 4$$

Left Side \neq Right Side

So, $\theta = 180^\circ$ is not a solution.

Check for $\theta = 270^\circ$:

$$\text{Left Side} = 5 \cos^2 \theta$$

$$= 5 \cos^2 270^\circ$$

$$= 5(0)^2$$

$$= 0$$

$$\text{Right Side} = -4 \cos \theta$$

$$= -4 \cos 270^\circ$$

$$= -4(0)$$

$$= 0$$

Left Side = Right Side

So, $\theta = 270^\circ$ is a solution.

Section 4.4 Page 212 Question 9

a) In step 1, they should not divide both sides by $\sin \theta$ because this may eliminate one possible solution and if $\sin \theta = 0$ this division is not permissible.

b) $2 \sin^2 \theta = \sin \theta$

$$2 \sin^2 \theta - \sin \theta = 0$$

$$\begin{aligned}\sin \theta (2 \sin \theta - 1) &= 0 \\ \sin \theta = 0 \text{ or } 2 \sin \theta - 1 &= 0 \\ \sin \theta &= \frac{1}{2}\end{aligned}$$

In the domain $0 < \theta \leq \pi$,

$$\theta = \pi \text{ or } \theta = \frac{\pi}{6}, \frac{5\pi}{6}$$

Section 4.4 Page 212 Question 10

$\sin \theta = 0$ when $\theta = 0$, $\theta = \pi$, or $\theta = 2\pi$. However the interval $(\pi, 2\pi)$ means $\pi < \theta < 2\pi$. There are no values of θ for which $\sin \theta = 0$ in this interval.

Section 4.4 Page 212 Question 11

The equation $\sin \theta = 2$ has no solution, because $\sin \theta$ has a maximum value of 1. This is true for all values of θ , so the interval is irrelevant.

Section 4.4 Page 212 Question 12

The trigonometric equation $\cos \theta = \frac{1}{2}$ does have an infinite number of solutions. Cosine is positive in quadrants I and IV, so in one positive rotation $\theta = 60^\circ$ and $\theta = 300^\circ$. However, all coterminal angles have the same value. In general, $\theta = 60^\circ + 360^\circ n$ or $\theta = 300^\circ + 360^\circ n$, where $n \in \mathbb{I}$.

Section 4.4 Page 212 Question 13

a) Check by substituting $\theta = \pi$ into the original equation.

$$\begin{aligned}\text{Left Side} &= 3 \sin^2 \theta - 2 \sin \theta \\ &= 3 \sin^2 \pi - 2 \sin \pi \\ &= 3(0)^2 - 2(0) \\ &= 0 \\ &= \text{Right Side}\end{aligned}$$

The solution $\theta = \pi$ is correct.

b) $3 \sin^2 \theta - 2 \sin \theta = 0$
 $\sin \theta (3 \sin \theta - 2) = 0$
 $\sin \theta = 0$ or $3 \sin \theta - 2 = 0$

$$\sin \theta = \frac{2}{3}$$

In the interval $\theta \in [0, \pi]$,

$\theta = 0, \pi$ or $\theta \approx 0.7297, 2.4119$

Section 4.4 Page 212 Question 14

Use $n_1 \sin \theta_1 = n_2 \sin \theta_2$

Solve for θ_2 when $\theta_1 = 35^\circ$, $n_1 = 1.00029$, and $n_2 = 1.33$.

$$1.00029 \sin 35^\circ = 1.33 \sin \theta_2$$

$$\frac{1.00029 \sin 35^\circ}{1.33} = \sin \theta_2$$

$$\theta_2 = \sin^{-1} \left(\frac{1.00029 \sin 35^\circ}{1.33} \right)$$

$$\theta_2 \approx 25.56^\circ$$

Section 4.4 Page 213 Question 15

a) For sales of 8300, substitute $y = 8.3$ into $y = 5.9 + 2.4 \sin \left(\frac{\pi}{6}(t-3) \right)$.

$$8.3 = 5.9 + 2.4 \sin \left(\frac{\pi}{6}(t-3) \right)$$

$$\frac{8.3 - 5.9}{2.4} = \sin \left(\frac{\pi}{6}(t-3) \right)$$

$$\sin^{-1} \left(\frac{2.4}{2.4} \right) = \frac{\pi}{6}(t-3)$$

$$\frac{\pi}{2} = \frac{\pi}{6}(t-3)$$

$$3 = t - 3$$

$$t = 6$$

Sales of 8300 air conditioners are expected in the sixth month, June.

b) Graph the function

$$y = 5.9 + 2.4 \sin \left(\frac{\pi}{6}(t-3) \right)$$

Minimum sales occur in the 12th month, December.

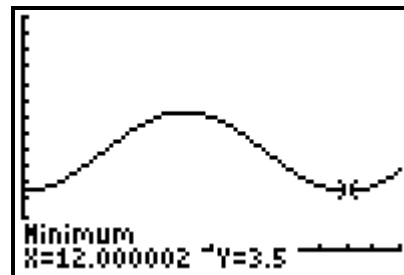

c) The formula seems reasonable. In western Canada you would expect sales of air conditioners to peak in summer and be least in winter.

Section 4.4 Page 213 Question 16

$$9 \sin^2 \theta + 12 \sin \theta + 4 = 0$$

$$(3 \sin \theta + 2)(3 \sin \theta + 2) = 0$$

$$3 \sin \theta + 2 = 0$$

$$\sin \theta = -\frac{2}{3}$$

$$\theta = \sin^{-1} \left(-\frac{2}{3} \right)$$

$$\approx -41.810\ 314\ 9$$

The reference angle is 41.8° , to the nearest tenth of a degree.

Sine is negative in quadrants III and IV. <This line was Nora's error>

The solution in quadrant III is $180^\circ + 41.8^\circ = 221.8^\circ$.

The solution in quadrant IV is $360^\circ - 41.8^\circ = 318.2^\circ$.

Section 4.4 Page 213 Question 17

Examples:

An equation such as $\cos x = 3$ has no solution because the maximum value of cosine is 1.

An equation such as $\sin x = -1$, $0 < x < \pi$, has no solution in the required interval, because

$$\sin^{-1}(-1) = \frac{3\pi}{2}.$$

Section 4.4 Page 213 Question 18

Given $\cot \theta = \frac{3}{4}$, and θ is in quadrant III so $x = -3$ and $y = -4$. Using the Pythagorean theorem, $r = 5$.

$$\text{Then, } \sec \theta = \frac{r}{x} = \frac{5}{-3}.$$

Section 4.4 Page 213 Question 19

a) For the ball at sea level, substitute $h = 0$.

$$h = 1.4 \sin\left(\frac{\pi t}{3}\right)$$

$$0 = 1.4 \sin\left(\frac{\pi t}{3}\right)$$

$$0 = \sin\left(\frac{\pi t}{3}\right)$$

Therefore, $\frac{\pi t}{3} = 0, \frac{\pi t}{3} = \pi, \frac{\pi t}{3} = 2\pi, \dots$

So, in the first 10 s, the beach ball is at sea level at 0 s, 3 s, 6 s, and 9 s.

b) The ball will reach its maximum height, for the first time, half way between 0s and 3s which is at 1.5 s. This will repeat every 6 s, so an expression for the time that the maximum occurs is $1.5 + 6n, n \in \mathbb{W}$.

A graph of the function $y = 1.4 \sin\left(\frac{\pi t}{3}\right)$ confirms

this reasoning.

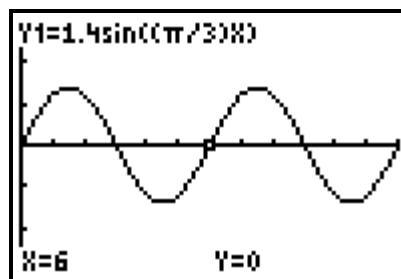

c) Since sine has minimum value -1 , the minimum value of $y = 1.4 \sin\left(\frac{\pi t}{3}\right)$ is -1.4 . So

the most the ball goes below sea level is 1.4 m.

Section 4.4 Page 213 Question 20

a) $I = 4.3 \sin 120\pi t$

Substitute $I = 0$, then $0 = 4.3 \sin 120\pi t$

$$0 = \sin 120\pi t$$

$$\sin \theta = 0 \text{ at } \theta = 0, \pi, 2\pi, \dots$$

$$0 = 120\pi t \rightarrow t = 0$$

$$\pi = 120\pi t \rightarrow t = \frac{1}{120}$$

$$2\pi = 120\pi t \rightarrow t = \frac{1}{60}$$

Since the current must alternate from 0 to positive back to 0 and then negative back to 0, it will take $\frac{1}{60}$ s for one complete cycle or 60 cycles in one second.

b) Each complete cycle takes $\frac{1}{60}$ s, so to reach the first maximum will take one-quarter of that time period or $\frac{1}{240}$ s. As a decimal this is approximately 0.004 167 s.

The cycle repeats every $\frac{1}{60}$ s, so in general the current reaches its maximum value at $\left(\frac{1}{240} + \frac{1}{60}n\right)$ seconds, where $n \in \mathbb{W}$. A graph of $y = 4.3 \sin 120\pi t$ confirms these results.

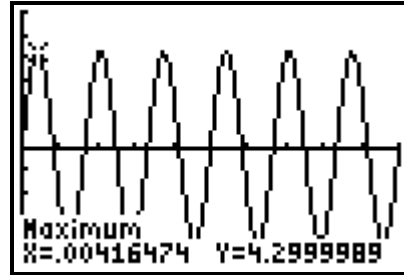

c) The current is at its first minimum value at $\left(\frac{3}{4}\right)\left(\frac{1}{60}\right)$ or $\frac{1}{80}$ s. As a decimal, this is 0.0125. So in general, the current reaches its minimum value at $\left(0.0125 + \frac{1}{60}n\right)$ seconds, where $n \in \mathbb{W}$.

d) The maximum value of sine is 1, so the maximum value of this function is 4.3. The maximum current is 4.3 amps.

Section 4.4 Page 214 Question 21

$$\cos\left(x - \frac{\pi}{2}\right) = \frac{\sqrt{3}}{2}$$

The reference angle for $\cos^{-1}\left(\frac{\sqrt{3}}{2}\right)$ is $\frac{\pi}{6}$. Cosine is positive in quadrants I and IV.

So, in the domain $-\pi < x < \pi$,

$$x - \frac{\pi}{2} = \frac{\pi}{6} \text{ or } x - \frac{\pi}{2} = -\frac{\pi}{6}$$

$$x = \frac{2\pi}{3} \text{ or } x = \frac{\pi}{3}$$

Section 4.4 Page 214 Question 22

a) The left side of the equation, $\sin^2 \theta + \sin \theta - 1$, has the form $x^2 + x - 1$ and cannot be factored.

b) In the quadratic formula, $x = \frac{-b \pm \sqrt{b^2 - 4ac}}{2a}$, substitute $a = 1$, $b = 1$, $c = -1$.

$$\begin{aligned}\sin \theta &= \frac{-(1) \pm \sqrt{(1)^2 - 4(1)(-1)}}{2(1)} \\ &= \frac{-1 \pm \sqrt{5}}{2}\end{aligned}$$

The only solution that makes sense is $\frac{-1 + \sqrt{5}}{2}$; the other solution is less than -1 which is not a possible value for sine.

c) From b), $\theta = \sin^{-1}\left(\frac{-1 + \sqrt{5}}{2}\right)$ or $\theta \approx 0.67$.

This is the solution in quadrant I. In the domain $0 < \theta \leq 2\pi$, there is another solution, in quadrant II. $\theta \approx \pi - 0.668 = 2.48$.

Section 4.4 Page 214 Question 23

a) The height of the trapezoid is $4 \sin \theta$ and the base of the trapezoid is $4 + 2 \cos \theta$.

Then, use the formula for the area of a trapezoid:

$$\begin{aligned}A &= \left(\frac{\text{sum of parallel sides}}{2} \right) h \\ &= \left(\frac{4 + 4 + 2(4 \cos \theta)}{2} \right) 4 \sin \theta \\ &= (8 + 8 \cos \theta) 2 \sin \theta \\ &= 16 \sin \theta (1 + \cos \theta)\end{aligned}$$

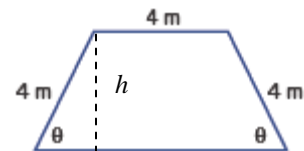

b) Substitute $A = 12\sqrt{3}$ in the formula from part a).

$$12\sqrt{3} = 16 \sin \theta (1 + \cos \theta)$$

$$\frac{12\sqrt{3}}{16} = \sin \theta (1 + \cos \theta)$$

$$\frac{3\sqrt{3}}{4} = \sin \theta (1 + \cos \theta)$$

$$\left(\frac{\sqrt{3}}{2}\right)\left(\frac{3}{2}\right) = \sin \theta (1 + \cos \theta)$$

Then, $\sin \theta = \frac{\sqrt{3}}{2}$ and $\cos \theta = \frac{1}{2}$ which is true when $\theta = \frac{\pi}{3}$.

c) Example: Graph the function $y = 16 \sin x (1 + \cos x)$ and identify the first maximum. The graph shown here is in radian mode.

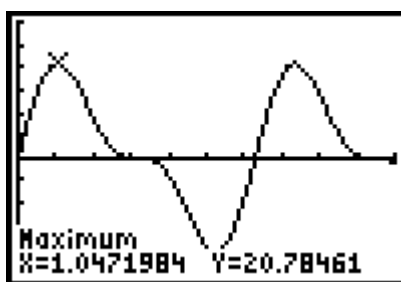
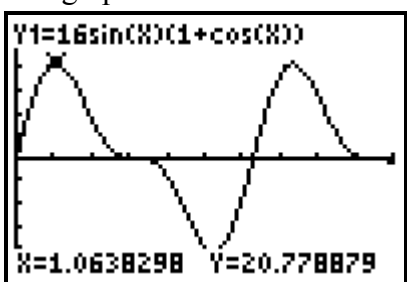

Section 4.4 Page 214 Question C1

The methods and steps used to simplify linear and quadratic trigonometric equations are the same as those used for linear and quadratic equations. The major difference is the last steps when the inverse of trigonometric ratios have to be used and consideration of signs and domain is needed.

Section 4.4 Page 214 Question C2

a) The point is on the unit circle if $x^2 + y^2 = 1$.

For A:

$$0.384\ 615\ 384\ 6^2 + 0.923\ 076\ 923\ 1^2 = 1$$

Therefore A is on the unit circle.

b) For a point on the unit circle,

$$\cos \theta = x$$

$$= 0.384\ 615\ 384\ 6$$

$$\approx 0.385$$

$$\begin{aligned}\csc \theta &= \frac{1}{y} \\ &= \frac{1}{0.923\ 076\ 923\ 1} \\ &\approx 1.083\end{aligned}$$

$$\begin{aligned}\tan \theta &= \frac{y}{x} \\ &= \frac{0.923\ 076\ 923\ 1}{0.384\ 615\ 384\ 6} \\ &\approx 2.400\end{aligned}$$

$$\begin{aligned}\text{c) } \theta &= \tan^{-1}(2.4) \\ &\approx 67.4^\circ\end{aligned}$$

This answer seems reasonable.

The x -coordinate is about one-third the y -coordinate, so the angle is about two-thirds of the rotation from 0° to 90° .

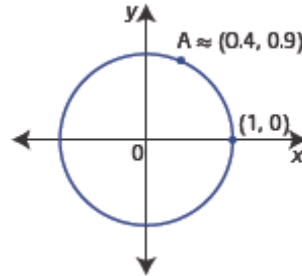

Section 4.4 Page 214 Question C3

a) Example: A non-permissible value is a value for which an expression is not defined. For a rational expression this is any value that would lead to division by 0. In the rational

equation $\frac{5}{x-1} = 9$, $x \neq 1$.

b) $\tan \theta = \frac{\sin \theta}{\cos \theta} = \frac{y}{x}$, so $\tan \theta$ is not defined for values that make $\cos \theta$ have value 0.

c) In the interval $0 \leq \theta < 4\pi$, $\cos \theta = 0$ when $\theta = \frac{\pi}{2}, \frac{3\pi}{2}, \frac{5\pi}{2}, \frac{7\pi}{2}$. These are the non-permissible values.

d) In general, $\tan \theta$ is not defined for $\theta = \frac{\pi}{2} + \pi n$, $n \in \mathbb{I}$.

Section 4.4 Page 214 Question C4

$$\begin{aligned}\text{a) } \quad 2 \sin^2 \theta &= 1 - \sin \theta \\ 2 \sin^2 \theta + \sin \theta - 1 &= 0 \\ (2 \sin \theta - 1)(\sin \theta + 1) &= 0 \\ 2 \sin \theta - 1 = 0 \text{ or } \sin \theta + 1 &= 0 \\ \sin \theta = \frac{1}{2} \text{ or } \sin \theta &= -1\end{aligned}$$

In the domain $0^\circ \leq \theta < 360^\circ$, $\theta = 30^\circ, 150^\circ$ or $\theta = 270^\circ$.

b) The solutions are exact because both values for $\sin \theta$ are special values.

c) To check, substitute the solution into both sides of the original equation. Both sides should have the same value.

Example $\theta = 270^\circ$:

Left Side = $2 \sin^2 \theta$	Right Side = $1 - \sin \theta$
= $2 \sin^2 270^\circ$	= $1 - \sin 270^\circ$
= $2(-1)^2$	= $1 - (-1)$
= $2(1)$	= $1 + 1$
= 2	= 2

Left Side = Right Side

Chapter 4 Review

Chapter 4 Review Page 215 Question 1

a) The terminal arm of 100° is in quadrant II.

b) $500^\circ - 360^\circ = 140^\circ$; so the terminal arm of 500° is in quadrant II.

c) $10 - 2\pi = 3.71$, $3.71 - \pi = 0.57$; so the terminal arm of 10 radians is in quadrant III.

d) $\frac{29\pi}{6} = 4\pi + \frac{5\pi}{6}$; so the terminal arm of the angle is in quadrant II.

Chapter 4 Review Page 215 Question 2

a) $\frac{5\pi}{2} = \frac{5(180^\circ)}{2}$
= 450°

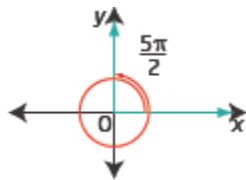

b) $240^\circ = 240 \left(\frac{\pi}{180} \right)$
= $\frac{4\pi}{3}$

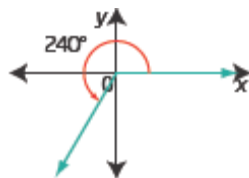

$$\begin{aligned} \text{c) } -405^\circ &= -405 \left(\frac{\pi}{180} \right) \\ &= -\frac{9\pi}{4} \end{aligned}$$

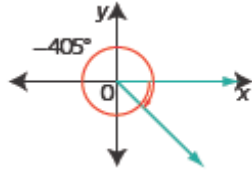

$$\begin{aligned} \text{d) } -3.5 &= -3.5 \left(\frac{180^\circ}{\pi} \right) \\ &= -\frac{630^\circ}{\pi} \end{aligned}$$

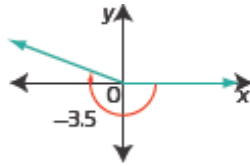

Chapter 4 Review Page 215 Question 3

$$\begin{aligned} \text{a) } 20^\circ &= 20 \left(\frac{\pi}{180} \right) \\ &\approx 0.35 \end{aligned}$$

$$\begin{aligned} \text{b) } -185^\circ &= -185 \left(\frac{\pi}{180} \right) \\ &\approx -3.23 \end{aligned}$$

$$\begin{aligned} \text{c) } -1.75 &= -1.75 \left(\frac{180^\circ}{\pi} \right) \\ &\approx -100.27^\circ \end{aligned}$$

$$\begin{aligned} \text{d) } \frac{5\pi}{12} &= \frac{5(180^\circ)}{12} \\ &= 75^\circ \end{aligned}$$

Chapter 4 Review Page 215 Question 4

a) $6.75 - 2\pi \approx 0.4668$.
The given angle is coterminal with 0.467 and terminates in quadrant I.

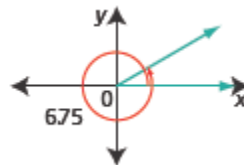

b) $400^\circ - 360^\circ = 40^\circ$.
The given angle is coterminal with 40° and terminates in quadrant I.

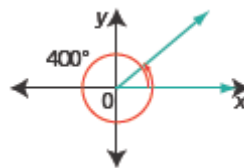

c) -3 is almost $-\pi$.
 $2\pi - 3 \approx 3.28$
The given angle is coterminal with 3.28 and terminates in quadrant III.

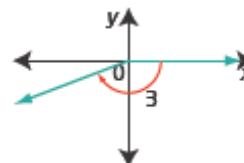

- d) -105° is a negative rotation, past -90° .
 $360^\circ - 105^\circ = 255^\circ$
 The given angle is coterminal with 255°
 and terminates in quadrant III.

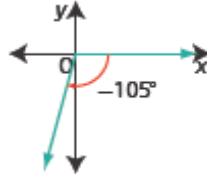

Chapter 4 Review Page 215 Question 5

- a) All angles coterminal with 250° are given by the expression $250^\circ \pm (360^\circ)n$, where n is any natural number.
- b) All angles coterminal with $\frac{5\pi}{2}$ are given by the expression $\frac{5\pi}{2} \pm 2\pi n$, where n is any natural number.
- c) All angles coterminal with -300° are given by the expression $-300^\circ \pm (360^\circ)n$, where n is any natural number.
- d) All angles coterminal with 6 radians are given by the expression $6 \pm 2\pi n$, where n is any natural number.

Chapter 4 Review Page 215 Question 6

- a) $80\,000 \text{ rpm} = 80\,000(2\pi)$, or $160\,000\pi$ radians per minute.
- b) $80\,000 \text{ rpm} = 80\,000(360)$ degrees per minute

$$= \frac{80\,000(360^\circ)}{60}$$

$$= 480\,000^\circ/\text{s}$$

Chapter 4 Review Page 215 Question 7

a) $P\left(\frac{5\pi}{6}\right) = \left(-\frac{\sqrt{3}}{2}, \frac{1}{2}\right)$

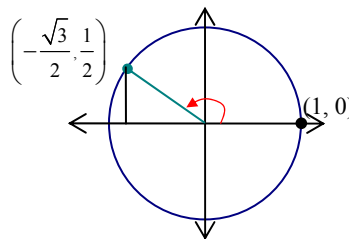

b) $P(-150^\circ) = \left(-\frac{\sqrt{3}}{2}, -\frac{1}{2}\right)$

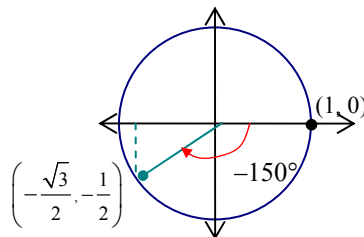

c) $-\frac{11\pi}{2}$ is coterminal with $\frac{\pi}{2}$, so $P\left(-\frac{11\pi}{2}\right) = (0, 1)$.

d) $P(45^\circ) = \left(\frac{\sqrt{2}}{2}, \frac{\sqrt{2}}{2}\right)$

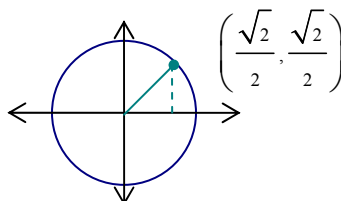

e) $P(120^\circ) = \left(-\frac{1}{2}, \frac{\sqrt{3}}{2}\right)$

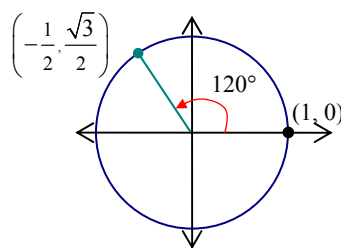

f) $\frac{11\pi}{3}$ is coterminal with $\frac{5\pi}{3}$.

So, $P\left(\frac{11\pi}{3}\right) = \left(\frac{1}{2}, -\frac{\sqrt{3}}{2}\right)$.

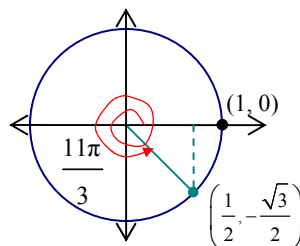

Chapter 4 Review Page 216 Question 8

a) The diagram shows $P\left(\frac{\pi}{3}\right)$, with coordinates $\left(\frac{1}{2}, \frac{\sqrt{3}}{2}\right)$. Then, $P\left(\frac{2\pi}{3}\right)$ will be the same distance from each axis as $P\left(\frac{\pi}{3}\right)$ is, but in quadrant II. So, its coordinates are $\left(-\frac{1}{2}, \frac{\sqrt{3}}{2}\right)$.

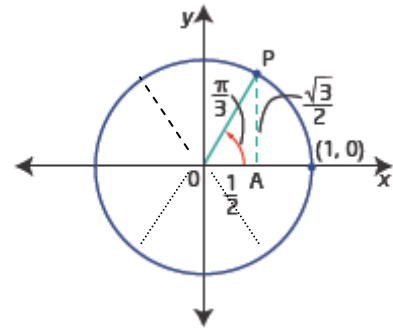

$P\left(\frac{4\pi}{3}\right)$ will be the same distance from each axis, but in quadrant III. So, its coordinates are $\left(-\frac{1}{2}, -\frac{\sqrt{3}}{2}\right)$. Similarly, $P\left(\frac{5\pi}{3}\right)$ will be the same distance from each axis, but in quadrant IV. So, its coordinates are $\left(\frac{1}{2}, -\frac{\sqrt{3}}{2}\right)$.

b) If $P(\theta) = \left(-\frac{2\sqrt{2}}{3}, \frac{1}{3}\right)$, then θ is in quadrant II.

$P\left(\theta + \frac{\pi}{2}\right)$ will be in quadrant III and will have coordinates $\left(-\frac{1}{3}, -\frac{2\sqrt{2}}{3}\right)$.

c) $P\left(\frac{5\pi}{6}\right)$ is in quadrant II. Then, $P\left(\frac{5\pi}{6} + \pi\right)$, which is a rotation of π more, will be in

$$\begin{aligned} \text{quadrant IV. } P(\theta) &= P\left(\frac{5\pi}{6} + \pi\right) \\ &= P\left(\frac{11\pi}{6}\right) \\ &= \left(\frac{\sqrt{3}}{2}, -\frac{1}{2}\right) \end{aligned}$$

Chapter 4 Review Page 216 Question 9

In the interval $-2\pi \leq \theta < 2\pi$:

a) $(0, 1)$ is on the y -axis, above the origin, so $\theta = -\frac{3\pi}{2}$ and $\theta = \frac{\pi}{2}$.

b) $\left(\frac{\sqrt{3}}{2}, -\frac{1}{2}\right)$ is in quadrant IV.

$\theta = -\frac{\pi}{6}$ and $\theta = \frac{11\pi}{6}$.

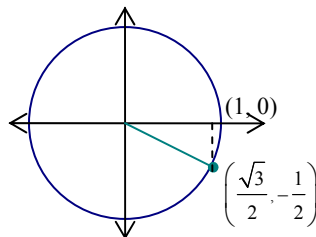

c) $\left(-\frac{1}{\sqrt{2}}, \frac{1}{\sqrt{2}}\right)$ is in quadrant II.

$\theta = -\frac{5\pi}{4}$ and $\theta = \frac{3\pi}{4}$.

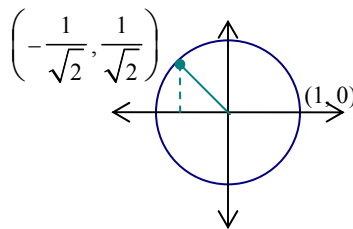

d) $\left(-\frac{1}{2}, \frac{\sqrt{3}}{2}\right)$ is in quadrant II.

$\theta = -\frac{4\pi}{3}$ and $\theta = \frac{2\pi}{3}$.

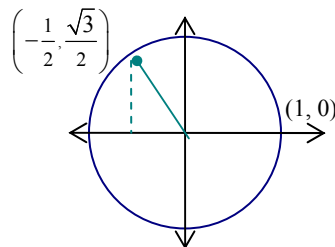

Chapter 4 Review Page 216 Question 10

In the domain $-180^\circ < \theta \leq 360^\circ$:

a) $\left(-\frac{\sqrt{3}}{2}, -\frac{1}{2}\right)$ is in quadrant

III.

$\theta = -150^\circ$ and $\theta = 210^\circ$.

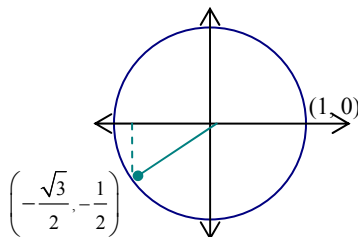

b) $(-1, 0)$ is on the x -axis to the left of the origin.

$\theta = 180^\circ$.

c) $\left(-\frac{\sqrt{2}}{2}, \frac{\sqrt{2}}{2}\right)$ is in quadrant II.
 $\theta = 135^\circ$.

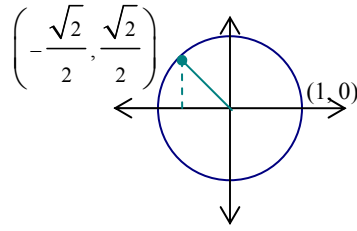

d) $\left(\frac{1}{2}, -\frac{\sqrt{3}}{2}\right)$ is in quadrant IV.
 $\theta = -60^\circ$ and $\theta = 300^\circ$.

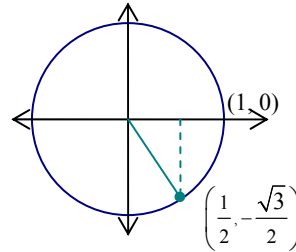

Chapter 4 Review Page 216 Question 11

a) Given $P(\theta) = \left(\frac{\sqrt{5}}{3}, -\frac{2}{3}\right)$, then θ is in quadrant IV.

$$\begin{aligned} \tan \theta &= \frac{y}{x} \\ &= -\frac{2}{3} \div \frac{\sqrt{5}}{3} \\ &= -\frac{2}{\sqrt{5}} \end{aligned}$$

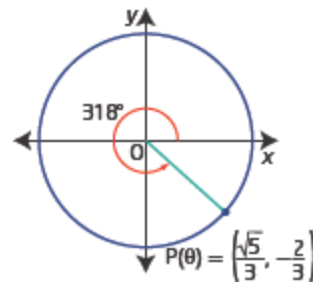

Then, $\theta \approx -42^\circ$ or 318° , or (in radians) $\theta \approx 5.55$.

b) θ terminates in quadrant IV.

c) $P(\theta + \pi)$ will be in quadrant II with coordinates $\left(-\frac{\sqrt{5}}{3}, \frac{2}{3}\right)$.

d) $P\left(\theta + \frac{\pi}{2}\right)$ will be in quadrant I with coordinates $\left(\frac{2}{3}, \frac{\sqrt{5}}{3}\right)$.

e) $P\left(\theta - \frac{\pi}{2}\right)$ will be in quadrant III with coordinates $\left(-\frac{2}{3}, -\frac{\sqrt{5}}{3}\right)$.

Chapter 4 Review Page 216 Question 12

If $\cos \theta = \frac{1}{3}$, $0^\circ \leq \theta \leq 270^\circ$, then θ is in quadrant I.

$$\cos \theta = \frac{x}{r}, \text{ so } x = 1 \text{ and } r = 3.$$

Determine y :

$$x^2 + y^2 = r^2$$

$$1^2 + y^2 = 3^2$$

$$y^2 = 8$$

$$y = \sqrt{8} \text{ or } 2\sqrt{2}$$

$$\text{Then, } \sin \theta = \frac{y}{r} = \frac{2\sqrt{2}}{3}$$

$$\tan \theta = \frac{y}{x} = \frac{2\sqrt{2}}{1} = 2\sqrt{2}$$

$$\csc \theta = \frac{r}{y} = \frac{3}{2\sqrt{2}} \text{ or } \frac{3\sqrt{2}}{4}$$

$$\sec \theta = \frac{r}{x} = \frac{3}{1} = 3$$

$$\cot \theta = \frac{x}{y} = \frac{1}{2\sqrt{2}} \text{ or } \frac{\sqrt{2}}{4}$$

Chapter 4 Review Page 216 Question 13

a) The terminal arm of $-\frac{3\pi}{2}$ is on the y -axis, above the origin. On the unit circle, its coordinates are $(0, 1)$.

$$\begin{aligned} \sin \left(-\frac{3\pi}{2} \right) &= \frac{y}{r} \\ &= \frac{1}{1} \\ &= 1 \end{aligned}$$

b) The terminal arm of $\frac{3\pi}{4}$ is in quadrant II. Its reference angle is $\frac{\pi}{4}$

$$\begin{aligned} \cos \frac{3\pi}{4} &= \frac{x}{r} \\ &= \frac{-\sqrt{2}}{2} \\ &= -\frac{\sqrt{2}}{2} \end{aligned}$$

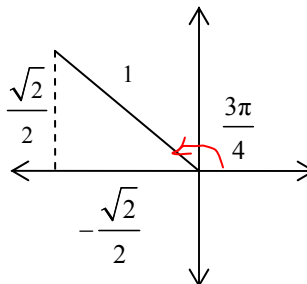

c) The terminal arm of $\frac{7\pi}{6}$ is in quadrant III. Its reference angle is $\frac{\pi}{6}$.

$$\begin{aligned}\cot \frac{7\pi}{6} &= \frac{x}{y} \\ &= \frac{-\frac{\sqrt{3}}{2}}{-\frac{1}{2}} \\ &= \sqrt{3}\end{aligned}$$

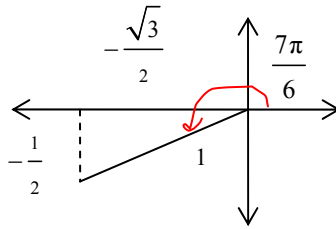

d) The terminal arm of -210° is in quadrant II. Its reference angle is 30° .

$$\begin{aligned}\sec(-210^\circ) &= \frac{r}{x} \\ &= \frac{1}{-\frac{\sqrt{3}}{2}} \\ &= -\frac{2}{\sqrt{3}} \text{ or } -\frac{2\sqrt{3}}{3}\end{aligned}$$

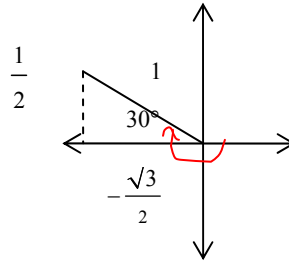

e) The terminal arm of 720° is coterminal with 0° . On the unit circle, its coordinates are $(1, 0)$.

$$\begin{aligned}\tan 720^\circ &= \frac{y}{x} \\ &= \frac{0}{1} \\ &= 0\end{aligned}$$

f) The terminal arm of 300° is in quadrant IV. Its reference angle is 60° .

$$\begin{aligned}\csc 300^\circ &= \frac{r}{y} \\ &= \frac{1}{-\frac{\sqrt{3}}{2}} \\ &= -\frac{2}{\sqrt{3}} \text{ or } -\frac{2\sqrt{3}}{3}\end{aligned}$$

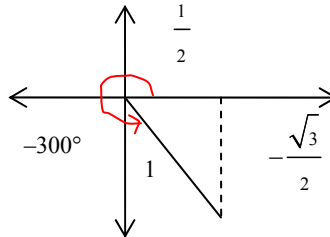

Chapter 4 Review Page 216 Question 14

a) $\sin \theta = 0.54$, $-2\pi < \theta \leq 2\pi$. The sine value is positive, so θ is in quadrant I or II.
 $\theta \approx 0.57, 2.57, -5.71, -3.71$

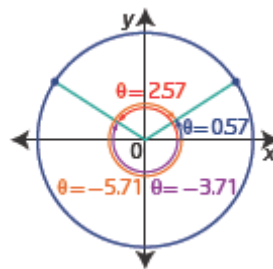

b) $\tan \theta = 9.3$, $-180^\circ \leq \theta < 360^\circ$. Since the tangent value is positive, θ is in quadrant I or III.
 $\theta \approx 83.86^\circ, 263.86^\circ, -96.14^\circ$

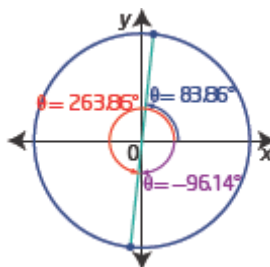

c) $\cos \theta = -0.77$, $-\pi \leq \theta < \pi$. The cosine value is negative, so θ is in quadrant II or III.
 $\theta \approx 2.45, -2.45$

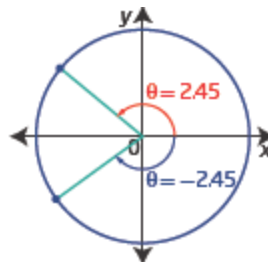

d) $\csc \theta = 9.5$, $-270^\circ < \theta \leq 90^\circ$. The cosecant value, and therefore the sine value, is positive, so θ is in quadrant I or II.
 $\theta \approx 6.04^\circ, -186.04^\circ$

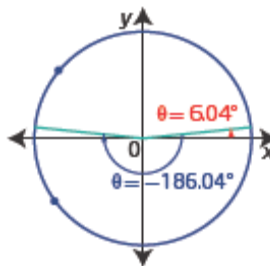

Chapter 4 Review Page 217 Question 15

a) $\sin 285^\circ \approx -0.966$

b) $\cot 130^\circ \approx -0.839$

c) $\cos 4.5 \approx -0.211$

d) $\sec 7.38 \approx 2.191$

Chapter 4 Review Page 217 Question 16

a) Example: $A(-3, 4)$ is in quadrant II.
The angle of rotation measures approximately 125° .

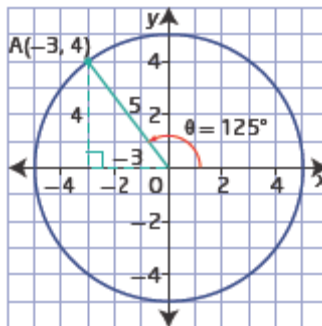

b) $\cos \theta = \frac{x}{r}$
 $= \frac{-3}{5}$ or -0.6

c) $\csc \theta + \tan \theta = \frac{r}{y} + \frac{y}{x}$
 $= \frac{5}{4} + \frac{4}{-3}$
 $= \frac{15 + (-16)}{12}$
 $= -\frac{1}{12}$

d) $\theta = \cos^{-1}(-0.6)$
 $= 126.9^\circ$, or 2.2

Chapter 4 Review Page 217 Question 17

a) $\cos^2 \theta + \cos \theta$
 $= \cos \theta (\cos \theta + 1)$

b) $\sin^2 \theta - 3 \sin \theta - 4$
 $= (\sin \theta - 4)(\sin \theta + 1)$

c) $\cot^2 \theta - 9$
 $= (\cot \theta - 3)(\cot \theta + 3)$

d) $2 \tan^2 \theta - 9 \tan \theta + 10$
 $= (2 \tan \theta - 5)(\tan \theta - 2)$

Chapter 4 Review Page 217 Question 18

a) $\sin^{-1} 2$ is impossible because the sine value of an angle is never 2. Sine has a maximum value of 1.

b) $\tan 90^\circ$ is not defined because $\tan = \frac{y}{x}$ and 90° is on the y -axis, so x is 0. Division by 0 is not permissible.

Chapter 4 Review Page 217 Question 19

a) $4 \cos \theta - 3 = 0$

$$\cos \theta = \frac{3}{4} \text{ or } 0.75$$

The cosine ratio is positive in quadrants I and IV, so there are two solutions in the domain $0^\circ < \theta \leq 360^\circ$.

b) $\sin \theta + 0.9 = 0$

$$\sin \theta = -0.9$$

The sine ratio is negative in quadrants III and IV, so there are two solutions (both negative) in the domain $-\pi \leq \theta \leq \pi$.

c) $0.5 \tan \theta - 1.5 = 0$

$$\tan \theta = 3$$

The tangent ratio is positive in quadrants I and III, so there is one solution (in quadrant III) in the domain $-180^\circ \leq \theta \leq 0^\circ$.

d) $\csc \theta$ is undefined. This occurs when $y = 0$. So, in the interval $\theta \in [-2\pi, 4\pi]$ there will be two angles which have their terminal arm on the y -axis in each of the three complete rotation, giving a total of six solutions.

Chapter 4 Review Page 217 Question 20

a) $\csc \theta = \sqrt{2}$, so $\sin \theta = \frac{1}{\sqrt{2}}$. The sine ratio is positive in quadrants I and II. The angle has reference angle 45° . Then, in the interval $\theta \in [0^\circ, 360^\circ]$, $\theta = 45^\circ$ and 135° .

b) $2 \cos \theta + 1 = 0$, so $\cos \theta = -\frac{1}{2}$. The cosine ratio is negative in quadrants II and III.

The reference angle is $\frac{\pi}{3}$. Then, in the domain $0 \leq \theta < 2\pi$, $\theta = \frac{2\pi}{3}$ and $\theta = \frac{4\pi}{3}$.

c) $3 \tan \theta - \sqrt{3} = 0$, so $\tan \theta = \frac{\sqrt{3}}{3}$ or $\frac{1}{\sqrt{3}}$. The tangent ratio is positive in quadrants I and III. The angle has reference angle 30° . Then, in the domain $-180^\circ \leq \theta < 360^\circ$, $\theta = 30^\circ, 210^\circ$, and -150° .

d) $\cot \theta + 1 = 0$, so $\cot \theta = -1$. This means $\tan \theta = -1$ too. The tangent ratio is negative in quadrants II and IV. The angle has reference angle $\frac{\pi}{4}$. Then, in the domain $-\pi \leq \theta < \pi$,

$$\theta = \frac{3\pi}{4} \text{ and } -\frac{\pi}{4}.$$

Chapter 4 Review Page 217 Question 21

a) $\sin^2 \theta + \sin \theta - 2 = 0$
 $(\sin \theta + 2)(\sin \theta - 1) = 0$
 $\sin \theta = -2$ or $\sin \theta = 1$

The first equation yields no solution. In the domain $0 \leq \theta < 2\pi$, $\sin \theta = 1$ for $\theta = \frac{\pi}{2}$.

b) $\tan^2 \theta + 3 \tan \theta = 0$
 $\tan \theta (\tan \theta + 3) = 0$
 $\tan \theta = 0$ or $\tan \theta = -3$
 In the domain $0^\circ < \theta \leq 360^\circ$,
 $\theta = 180^\circ, 360^\circ$ or $\theta \approx 108.435^\circ, 288.435^\circ$

c) $6 \cos^2 \theta + \cos \theta = 1$
 $6 \cos^2 \theta + \cos \theta - 1 = 0$
 $(3 \cos \theta - 1)(2 \cos \theta + 1) = 0$
 $\cos \theta = \frac{1}{3}$ or $\cos \theta = -\frac{1}{2}$
 In the interval $\theta \in (0^\circ, 360^\circ)$,
 $\theta \approx 70.529^\circ, 289.471^\circ$ or $\theta = 120^\circ, 240^\circ$

d) $\sec^2 \theta - 4 = 0$
 $(\sec \theta - 2)(\sec \theta + 2) = 0$
 $\sec \theta = \pm 2$
 $\cos \theta = \pm \frac{1}{2}$

In the interval $\theta \in [-\pi, \pi]$, $\theta = -\frac{2\pi}{3}, -\frac{\pi}{3}, \frac{\pi}{3}, \frac{2\pi}{3}$.

Chapter 4 Review Page 217 Question 22

For $\sin \theta = \frac{\sqrt{3}}{2}$, the angle must be in quadrant I or II.

Examples:

a) In the domain $0 \leq \theta < 2\pi$, $\theta = \frac{\pi}{3}, \frac{2\pi}{3}$.

b) In the domain $-2\pi \leq \theta < \frac{\pi}{2}$, $\theta = -\frac{5\pi}{3}, -\frac{4\pi}{3}, \frac{\pi}{3}$.

c) In the domain $-720^\circ \leq \theta < 0^\circ$, $\theta = -660^\circ, -600^\circ, -300^\circ, -240^\circ$.

d) In the domain $-270^\circ \leq \theta < 450^\circ$, $\theta = -240^\circ, 60^\circ, 120^\circ, 420^\circ$.

Chapter 4 Review Page 217 Question 23

a) $\sin x = -\frac{1}{2}$, in radians. The sine ratio is negative, so x is in quadrants III or IV.

The reference angle is $\frac{\pi}{6}$.

In quadrant III, $x = \frac{7\pi}{6} + 2\pi n$, $n \in \mathbb{I}$

In quadrant IV, $x = \frac{11\pi}{6} + 2\pi n$, $n \in \mathbb{I}$

b) $\sin x = \sin^2 x$, in degrees.

$$\sin x - \sin^2 x = 0$$

$$\sin x(1 - \sin x) = 0$$

$$\sin x = 0 \text{ or } 1 - \sin x = 0$$

$$1 = \sin x$$

$$x = 0^\circ, 180^\circ \text{ or } x = 90^\circ$$

In general, $x = (180^\circ)n$, $n \in \mathbb{I}$ and $x = 90^\circ + (360^\circ)n$, $n \in \mathbb{I}$.

c) $\sec x + 2 = 0$, in degrees.

$$\sec x = -2, \text{ or } \cos x = -\frac{1}{2}$$

The cosine ratio is negative, so x is in quadrants II or III.

The reference angle is 60° .

In quadrant II, $x = 120^\circ + (360^\circ)n$, $n \in \mathbb{I}$
In quadrant III, $x = 240^\circ + (360^\circ)n$, $n \in \mathbb{I}$

d) $(\tan x - 1)(\tan x - \sqrt{3}) = 0$, in radians.

$$\tan x - 1 = 0 \quad \text{or} \quad \tan x - \sqrt{3} = 0$$

$$\tan x = 1 \quad \text{or} \quad \tan x = \sqrt{3}$$

$$\text{Then, } x = \frac{\pi}{4}, \frac{5\pi}{4} \quad \text{or} \quad x = \frac{\pi}{3}, \frac{4\pi}{3}$$

In general, $x = \frac{\pi}{4} + \pi n$, $n \in \mathbb{I}$ and $x = \frac{\pi}{3} + \pi n$, $n \in \mathbb{I}$.

Chapter 4 Practice Test

Chapter 4 Practice Test Page 218 Question 1

Given $\cos \theta = \frac{\sqrt{3}}{2}$, the reference angle for θ is $\frac{\pi}{6}$ and θ is in quadrant I or IV.

Of the possible answers, **D** is the best answer.

Chapter 4 Practice Test Page 218 Question 2

Given $\sin \theta = -\frac{\sqrt{3}}{2}$, $0^\circ \leq \theta < 360^\circ$. The sine ratio is negative in quadrants III and IV and the reference angle is 60° . So, $\theta = 240^\circ$ and 300° . **C** is the correct answer.

Chapter 4 Practice Test Page 218 Question 3

Given $\cot \theta = 1.4$, the cotangent ratio is positive in quadrants I and III.

In quadrant I, $\theta \approx 0.620$, and in quadrant III, $\theta \approx 3.762$.

Answer **A** is correct.

Chapter 4 Practice Test Page 218 Question 4

Given $P\left(-\frac{3}{4}, \frac{\sqrt{7}}{4}\right)$. For a 90° counterclockwise rotation the x -coordinate and y -

coordinate switch and signs are adjusted for the new quadrants. So $Q\left(-\frac{\sqrt{7}}{4}, -\frac{3}{4}\right)$.

Answer **B** is correct.

Chapter 4 Practice Test Page 218 Question 5

$$\sin \theta (\sin \theta + 1) = 0$$

In the domain $-180^\circ < \theta < 360^\circ$, $\sin \theta = 0$ at 0° and 180° . $\sin \theta = -1$ at -90° and 270° .

There are 4 solutions in the given domain. Answer **B** is correct.

Chapter 4 Practice Test Page 218 Question 6

a) Determine the circumference, to find the distance travelled in one rotation of the tire.

$$\begin{aligned} C &= \pi d \\ &= \pi(75) \end{aligned}$$

$$\begin{aligned} \text{Number of turns per second} &= \frac{110(1000)(\cancel{100})}{\pi(75)(\cancel{60})(\cancel{60})} \\ &\approx 12.968 \end{aligned}$$

So, a point on the tire moves through approximately $12.968(360^\circ)$ or 4668.5° each second. In radians, this is approximately 81.5 radians each second.

b) If the diameter of the tire is 66 cm, then

$$\begin{aligned} \text{Number of turns per second} &= \frac{110(1000)(\cancel{100})}{\pi(66)(\cancel{60})(\cancel{60})} \\ &\approx 14.737 \end{aligned}$$

A point on the tire moves through approximately $14.737(2\pi)$ or 92.6 radians each second.

The smaller tire has to make more turns to travel a given distance, so it will experience more tire wear.

Chapter 4 Practice Test Page 218 Question 7

a) The equation for any circle with centre the origin and radius 1 unit is

$$x^2 + y^2 = 1.$$

b) Substitute into the equation from part a) and solve for the missing coordinate.

$$\begin{aligned} \text{i) } \left(\frac{2\sqrt{3}}{5}\right)^2 + y^2 &= 1 \\ \frac{12}{25} + y^2 &= 1 \\ y^2 &= \frac{13}{25} \\ y &= \pm \frac{\sqrt{13}}{5} \end{aligned}$$

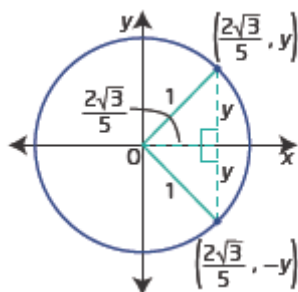

$$\begin{aligned} \text{ii) } x^2 + \left(\frac{\sqrt{7}}{4}\right)^2 &= 1 \\ x^2 + \frac{7}{16} &= 1 \\ x^2 &= \frac{9}{16} \\ x &= \pm \frac{3}{4} \end{aligned}$$

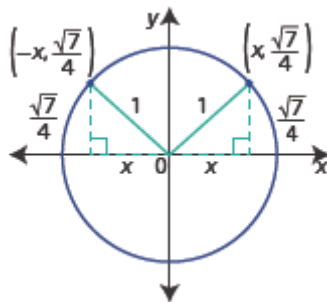

For $x < 0$, the missing value of x is $-\frac{3}{4}$.

c) Example: If you know the y -coordinate of a point on the unit circle then you can use the equation $x^2 + y^2 = 1$ to determine the corresponding x -coordinate. Then, the cosine is the same as the x -coordinate because in $\cos \theta = \frac{\text{adjacent}}{\text{hypotenuse}}$, the adjacent is the x -coordinate and the hypotenuse is 1 in the unit circle.

Chapter 4 Practice Test Page 219 Question 8

a) The cosine is negative when the angle is in quadrant II or III. If you have determined that the solution in quadrant III is A , then $A - \pi$ is the measure of the reference angle. The solution in quadrant II is $\pi - (A - \pi)$ or $2\pi - A$.

b) The general solution is given by each solution plus $2\pi n$, where $n \in \mathbb{I}$.

Chapter 4 Practice Test Page 219 Question 9

$$2 \cos \theta + \sqrt{2} = 0$$

$$2 \cos \theta = -\sqrt{2}$$

$$\cos \theta = -\frac{\sqrt{2}}{2}$$

The reference angle for θ is $\frac{\pi}{4}$. The cosine is negative when the angle is in quadrant II or III.

In quadrant II: $\theta = \frac{3\pi}{4} + 2\pi n$, where $n \in \mathbb{I}$.

In quadrant III: $\theta = \frac{5\pi}{4} + 2\pi n$, where $n \in \mathbb{I}$.

Chapter 4 Practice Test Page 219 Question 10

An angle measuring 3° is a very small angle with its terminal arm just above the x -axis in quadrant I, whereas 3 radians is a much larger angle, with its terminal arm close to the y -axis, in quadrant II.

Chapter 4 Practice Test Page 219 Question 11

a) $-500^\circ = -(360^\circ + 140^\circ)$, so the angle terminates in quadrant III.

b) The reference angle for -500° is $180^\circ - 140^\circ$, which is 40° .

c) Since the angle is in quadrant III,

$$\sin(-500^\circ) \approx -0.6, \cos(-500^\circ) \approx -0.8, \tan(-500^\circ) \approx 0.8$$

$$\csc(-500^\circ) \approx -1.6, \sec(-500^\circ) \approx -1.3, \cot(-500^\circ) \approx 1.2$$

Chapter 4 Practice Test Page 219 Question 12

a) For $\frac{13\pi}{4}$, one positive coterminal angle is $\frac{5\pi}{4}$, one negative coterminal angle is $-\frac{3\pi}{4}$. All coterminal angles are given by $\frac{5\pi}{4} \pm 2\pi n$, where $n \in \mathbb{N}$.

b) For -575° , one positive coterminal angle is 145° , one negative coterminal angle is -215° . All coterminal angles are given by $145^\circ \pm (360^\circ)n$, where $n \in \mathbb{N}$.

Chapter 4 Practice Test Page 219 Question 13

For the arc lengths, AB and CD, use the formula $a = \theta r$.

For the arc length AB:

$$AB = 1.48(1.3)$$

For the arc length CD:

$$CD = 2\pi(1)\frac{79}{360}$$

$$\begin{aligned} \text{Total length A to E} &= 1.48(1.3) + 1.9 + 2\pi(1)\frac{79}{360} + 2.5 \\ &\approx 7.7 \end{aligned}$$

The length of this stretch of road is 7.7 km, to the nearest tenth.

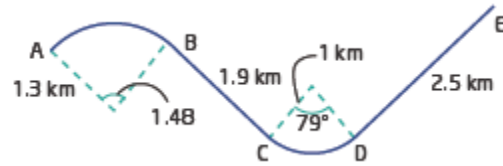

Chapter 4 Practice Test Page 219 Question 14

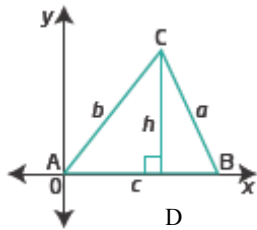

$$\begin{aligned} \text{Area } \triangle ABC &= \frac{1}{2}(\text{base})(\text{height}) \\ &= \frac{1}{2}ch \quad (1) \end{aligned}$$

In $\triangle ACD$, $\sin A = \frac{h}{b}$
 $h = b \sin A$

Alternatively, in $\triangle BCD$, $\sin B = \frac{h}{a}$
 $h = a \sin B$

Substitute for h in equation (1):

Substitute for h in equation (1):

$$\begin{aligned} \text{Area } \triangle ABC &= \frac{1}{2}cb \sin A \\ &= \frac{1}{2}bc \sin A \end{aligned}$$

$$\begin{aligned} \text{Area } \triangle ABC &= \frac{1}{2}ca \sin B \\ &= \frac{1}{2}ac \sin B \end{aligned}$$

Chapter 4 Practice Test Page 219 Question 15

a) $3 \tan^2 \theta - \tan \theta - 4 = 0$

$$(3 \tan \theta - 4)(\tan \theta + 1) = 0$$

$$\tan \theta = \frac{4}{3} \text{ or } \tan \theta = -1$$

Then, in the domain $-\pi < \theta < 2\pi$,

$$\theta \approx -2.21, 0.93, 4.07 \text{ or } \theta = -\frac{\pi}{4}, \frac{3\pi}{4}, \frac{7\pi}{4}$$

b) $\sin^2 \theta + \sin \theta - 1 = 0$

Use the quadratic formula with $a = 1$, $b = 1$ and $c = -1$.

$$\begin{aligned}\sin \theta &= \frac{-b \pm \sqrt{b^2 - 4ac}}{2a} \\ &= \frac{-1 \pm \sqrt{1^2 - 4(1)(-1)}}{2(1)} \\ &= \frac{-1 \pm \sqrt{5}}{2}\end{aligned}$$

Then, in the domain $0 \leq \theta < 2\pi$,

$$\theta \approx 0.67, 2.48$$

c) $\tan^2 \theta = 4 \tan \theta$

$$\tan^2 \theta - 4 \tan \theta = 0$$

$$\tan \theta(\tan \theta - 4) = 0$$

$$\tan \theta = 0 \text{ or } \tan \theta = 4$$

Then, in the interval $\theta \in [0, 2\pi]$,

$$\theta = 0, \pi, 2\pi \text{ or } \theta \approx 1.33, 4.47$$

Chapter 4 Practice Test Page 219 Question 16

Use a ratio to determine the arc length.

$$\frac{\text{arc length}}{\text{circumference}} = \frac{210}{360}$$

$$\frac{\text{arc length}}{2\pi(8)} = \frac{210}{360}$$

$$\text{arc length} = 16\pi \left(\frac{210}{360} \right)$$

$$= \frac{28\pi}{3}$$

$$\approx 29.32$$

Jack travelled 29.32 m, to the nearest hundredth of a metre.